

RADIO COMMUNICATIONS IN THE DIGITAL AGE

VOLUME ONE: HF TECHNOLOGY

HARRIS

First Printing, May 1996
Copyright © 1996
By Harris Corporation
All rights reserved

LIBRARY OF CONGRESS CATALOG CARD NUMBER: 96-94476
Harris Corporation, RF Communications Division
Radio Communications in the Digital Age
Volume One: HF Technology

Printed in USA
5/96 MG 25K
B1006
© Harris Corporation

All Harris RF Communications products and systems included herein
are trademarks of the Harris Corporation.

TABLE OF CONTENTS

INTRODUCTION	1	CHAPTER 7 SECURING COMMUNICATIONS	61
CHAPTER 1 PRINCIPLES OF RADIO COMMUNICATIONS	4	CHAPTER 8 HF SYSTEMS AND APPLICATIONS	67
CHAPTER 2 THE IONOSPHERE AND HF PROPAGATION	17	CHAPTER 9 FUTURE DIRECTIONS	83
CHAPTER 3 ELEMENTS IN AN HF RADIO SYSTEM	28	APPENDIX A STANDARDS	86
CHAPTER 4 NOISE AND INTERFERENCE	42	APPENDIX B GLOSSARY	88
CHAPTER 5 DATA COMMUNICATION VIA HF RADIO	47	FURTHER READING	101
CHAPTER 6 ADAPTIVE RADIO TECHNOLOGY	56		

Note: Throughout this handbook, technical terms and acronyms shown in italics are defined in the Glossary, Appendix B.

INTRODUCTION

There was a time when radio communication was one of a few methods for instant communication across distances. We've all seen black-and-white wartime film clips of radio operators sending Morse code using bulky radio equipment. After World War II, the communications industry turned its attention to other technologies, leading to a period of slow growth in high-frequency (*HF*) radio communications during the 1960s and 1970s. However, HF, also known as short wave, is now undergoing an exciting revival propelled by an infusion of new technology.

Genesis

Modern radio technology had its birth with the publication of James Clerk Maxwell's *Treatise on Electricity and Magnetism* in 1873, setting forth the basic theory of electromagnetic wave propagation.

But the first radio waves were actually detected 15 years later. In 1888, Heinrich Rudolph Hertz (the scientist for whom the unit of frequency is named) demonstrated that disturbances generated by a spark coil showed the characteristics of Maxwell's radio waves. His work inspired Guglielmo Marconi's early experiments with wireless telegraphy using Morse code. By 1896, Marconi had communicated messages over distances of a few kilometers.

It was thought at the time that radio waves in the atmosphere traveled in straight lines and that they therefore would not be useful for over-the-horizon communication. That opinion did not discourage Marconi, however, who became the first to demonstrate the transmission of radio waves over long distances. In

1901 in Newfoundland, Canada, he detected a telegraphic signal transmitted from Cornwall, England, 3,000 kilometers away. For an antenna, he used a wire 120 meters long, held aloft by a simple kite.

Marconi's success stimulated an intensive effort to explain and exploit his discovery. The question of how radio waves could be received around the surface of the earth was eventually answered by Edward Appleton. It was this British physicist who discovered that a blanket of electrically charged, or "ionized," particles in the earth's atmosphere (the *ionosphere*) were capable of reflecting radio waves. By the 1920s, scientists had applied this theory and developed ways to measure and predict the refractive properties of the ionosphere.

Growth

In time, the characteristics of HF radio propagation became better understood. Operators learned, for example, that usable frequencies varied considerably with time of day and season.

HF technology developed quickly. By World War II, HF radio was the primary means of long-haul communications for military commanders because it provided communications with land, sea, and air forces.

In the hands of a skilled operator, armed with years of experience and an understanding of the propagating effects of the ionosphere, HF radio was routinely providing reliable, effective links over many thousands of miles. Today, HF radio plays an important role in allowing emerging nations to establish a national communications system quickly and inexpensively.

Hiatus

The advent of long-range communications by satellite in the 1960s initiated a period of declining interest in HF radio. Satellites carried more channels and could handle data transmission at higher speeds. Additionally, satellite links seemed to eliminate the need for highly trained operators.

As long-range communications traffic migrated to satellites, HF was often relegated to a backup role. The result was user preference for wider bandwidth methods of communication, such as satellites, resulting in declining proficiency in HF as the number of experienced radio operators decreased.

It became clear over time, however, that satellites (for all their advantages) had significant limitations. Military users became increasingly concerned about the vulnerability of satellites to jamming and physical damage, and questioned the wisdom of depending exclusively on them. Moreover, satellites and their supporting infrastructure are expensive to build and maintain.

Revival

In the last decade, we've seen a resurgence in HF radio. Research and development activity has intensified, and a new generation of automated HF equipment has appeared. These systems provide dramatic improvements in link reliability and connectivity, while eliminating the tedious manual operating procedures required to use older generation equipment. Today's adaptive HF radios are as easy to use as wireless telephones.

Nonetheless, the perception that HF radio is an inherently difficult medium continues to linger. This perception continues only because some communicators remember how HF *used* to be.

As your interest in this book shows, however, *HF is again being recognized as a robust and highly competitive medium for long-haul communications*, offering myriad capabilities. In this introduction to HF radio communications, we present information that will help you understand modern HF radio technology. We'll cover the principles of HF radio, talk about specific applications, and then, consider the future of HF radio communication.

PRINCIPLES OF RADIO COMMUNICATIONS

Developing an understanding of radio communications begins with the comprehension of basic electromagnetic radiation.

Radio waves belong to the electromagnetic radiation family, which includes x-ray, ultraviolet, and visible light — forms of energy we use every day. Much like the gentle waves that form when a stone is tossed into a still lake, radio signals radiate outward, or *propagate*, from a transmitting antenna. However, unlike water waves, radio waves propagate at the speed of light.

We characterize a radio wave in terms of its *amplitude*, *frequency*, and *wavelength* (Figure 1-1).

Radio wave amplitude, or strength, can be visualized as its height — the distance between its peak and its lowest point. Amplitude, which is measured in volts, is usually expressed by engineers in terms of an average value called root-mean-square, or *RMS*.

The frequency of a radio wave is the number of repetitions or cycles it completes in a given period of time. Frequency is measured in hertz (*Hz*); one hertz equals one cycle per second. Thousands of hertz are expressed as kilohertz (kHz), and millions of hertz as megahertz (MHz). You would typically see a frequency of 2,182,000 hertz, for example, written as 2,182 kHz or 2.182 MHz.

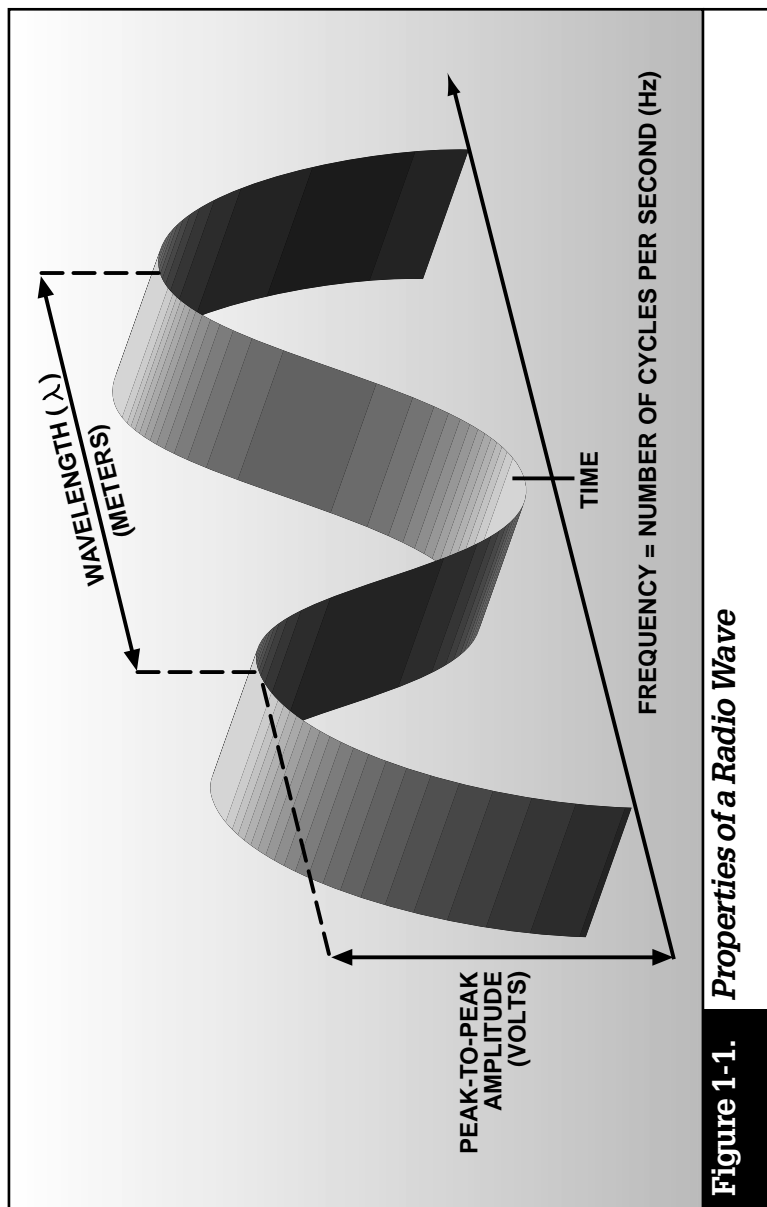

Figure 1-1. Properties of a Radio Wave

Radio wavelength is the distance between crests of a wave. The product of wavelength and frequency is a constant that is equal to the speed of propagation. Thus, as the frequency increases, wavelength decreases, and vice versa.

Since radio waves propagate at the speed of light (300 million meters per second), you can easily determine the wavelength in meters for any frequency by dividing 300 by the frequency in megahertz. So, the wavelength of a 10-MHz wave is 30 meters, determined by dividing 300 by 10.

The Radio Frequency Spectrum

In the radio frequency spectrum (Figure 1-2), the usable frequency range for radio waves extends from about 20 kHz (just above sound waves) to above 30,000 MHz. A wavelength at 20 kHz is 15 kilometers long. At 30,000 MHz, the wavelength is only 1 centimeter.

The HF band is defined as the frequency range of 3 to 30 MHz. In practice, most HF radios use the spectrum from 1.6 to 30 MHz. Most long-haul communications in this band take place between 4 and 18 MHz. Higher frequencies (18 to 30 MHz) may also be available from time to time, depending on ionospheric conditions and the time of day (see Chapter 2).

In the early days of radio, HF frequencies were called *short wave* because their wavelengths (10 to 100 meters) were shorter than those of commercial broadcast stations. The term is still applied to long-distance radio communications.

Frequency Allocations and Modulation

Within the HF spectrum, groups of frequencies are allocated to specific radio services — aviation, maritime, military, government, broadcast, or amateur (Figure 1-3). Frequencies are further regulated according to transmission type: emergency, broadcast, voice, Morse code, facsimile, and data. Frequency allocations are governed by international treaty and national licensing authorities.

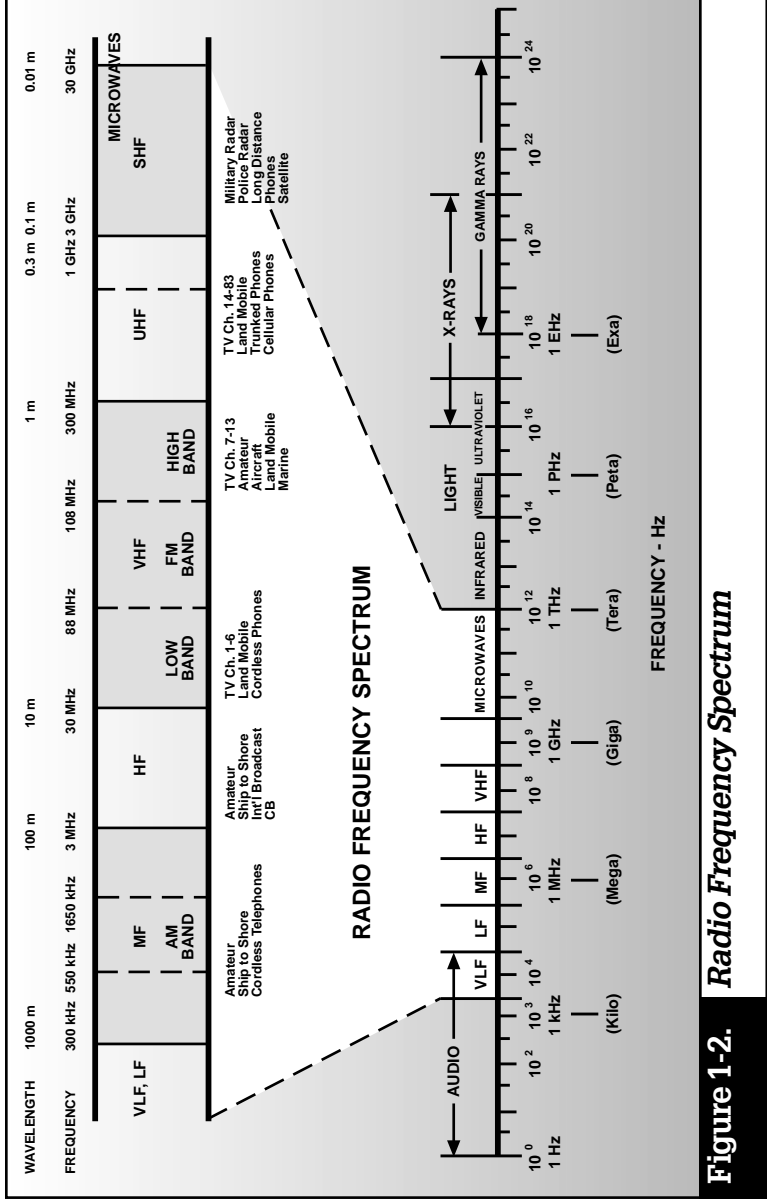

Figure 1-2.

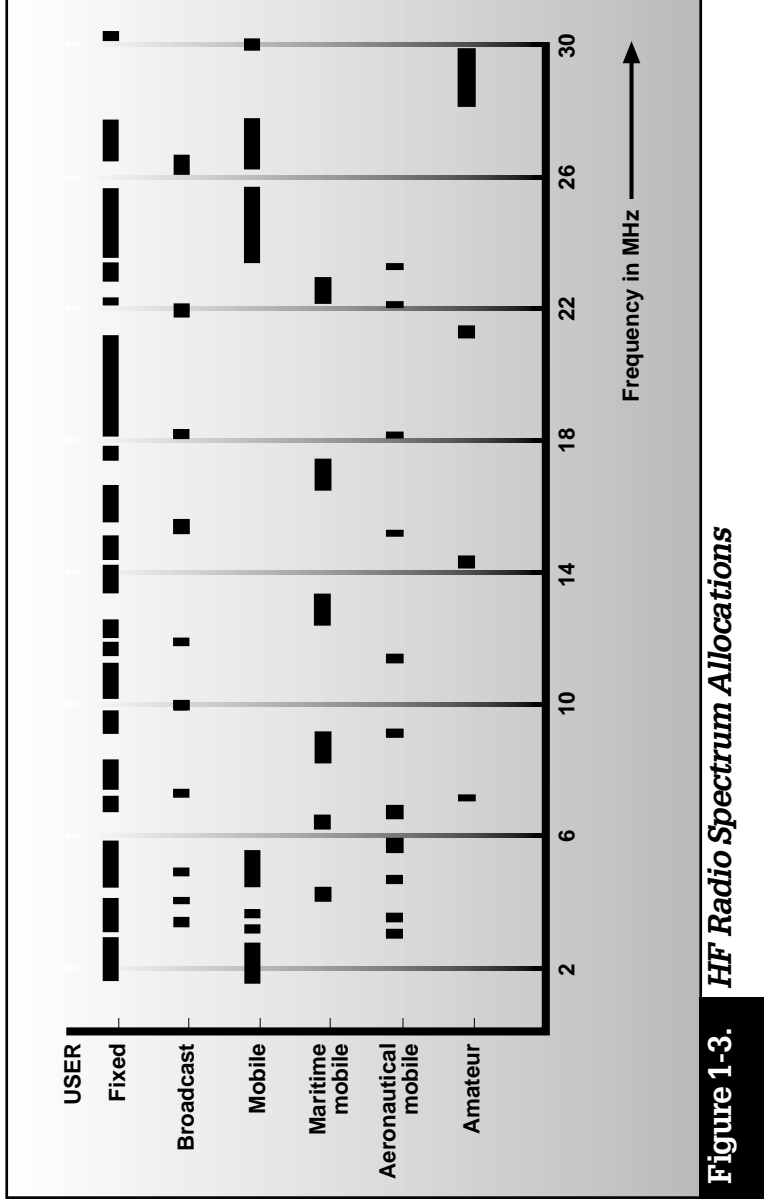

Figure 1-3.

The allocation of a frequency is just the beginning of radio communications. By itself, a radio wave conveys no information. It's simply a rhythmic stream of continuous waves (*CW*).

When we modulate radio waves to carry information, we refer to them as *carriers*. To convey information, a carrier must be varied so that its properties — its amplitude, frequency, or *phase* (the measurement of a complete wave cycle) — are changed, or *modulated*, by the information signal.

The simplest method of modulating a carrier is by turning it on and off by means of a telegraph key. *On-off keying*, using Morse code, was the only method of conveying wireless messages in the early days of radio.

Today's common methods for radio communications include amplitude modulation (*AM*), which varies the strength of the carrier in direct proportion to changes in the intensity of a source such as the human voice (Figure 1-4a). In other words, information is contained in amplitude variations.

The AM process creates a carrier and a pair of duplicate *sidebands* — nearby frequencies above and below the carrier (Figure 1-4b). AM is a relatively inefficient form of modulation, since the carrier must be continually generated. The majority of the power in an AM signal is consumed by the carrier that carries no information, with the rest going to the information-carrying sidebands.

In a more efficient technique, single sideband (*SSB*), the carrier and one of the sidebands are suppressed (Figure 1-4c). Only the remaining sideband, upper (*USB*) or lower (*LSB*), is transmitted. An SSB signal needs only half the *bandwidth* of an AM signal and is produced only when a modulating signal is present. Thus, SSB systems are more efficient both in the use of the spectrum, which must accommodate many users, and of transmitter power. All the transmitted power goes into the information-carrying sideband.

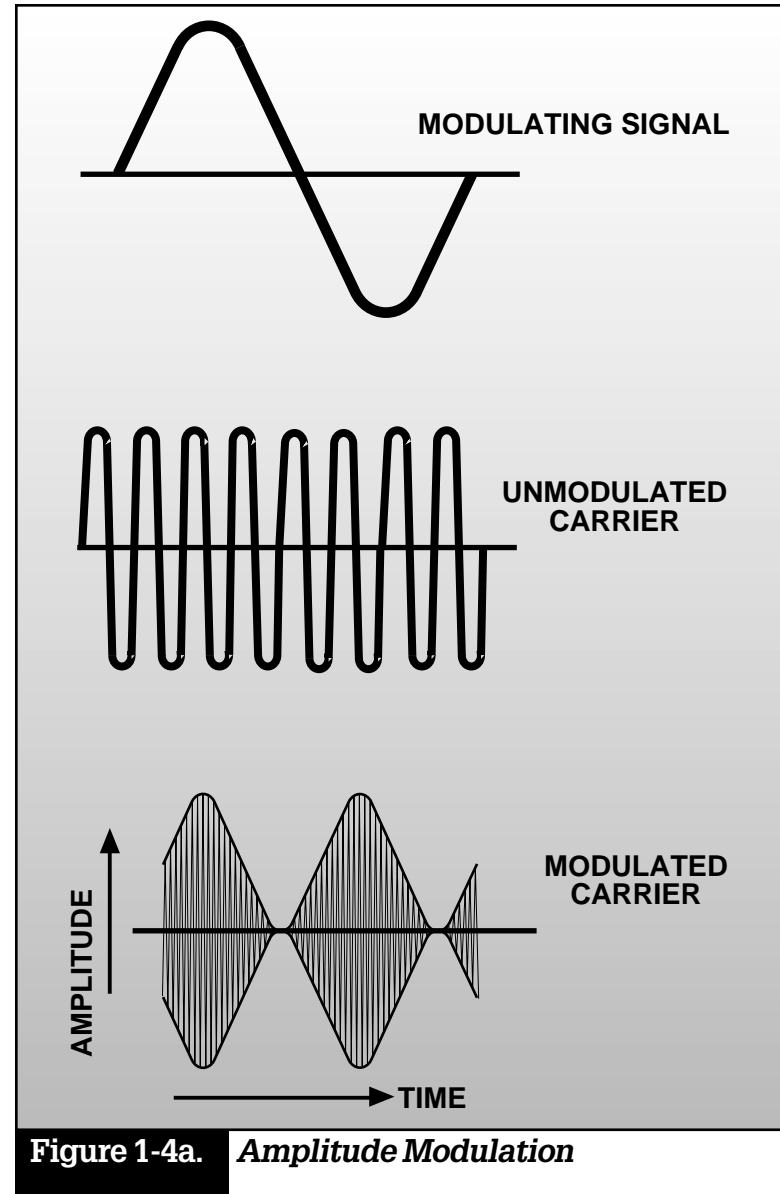
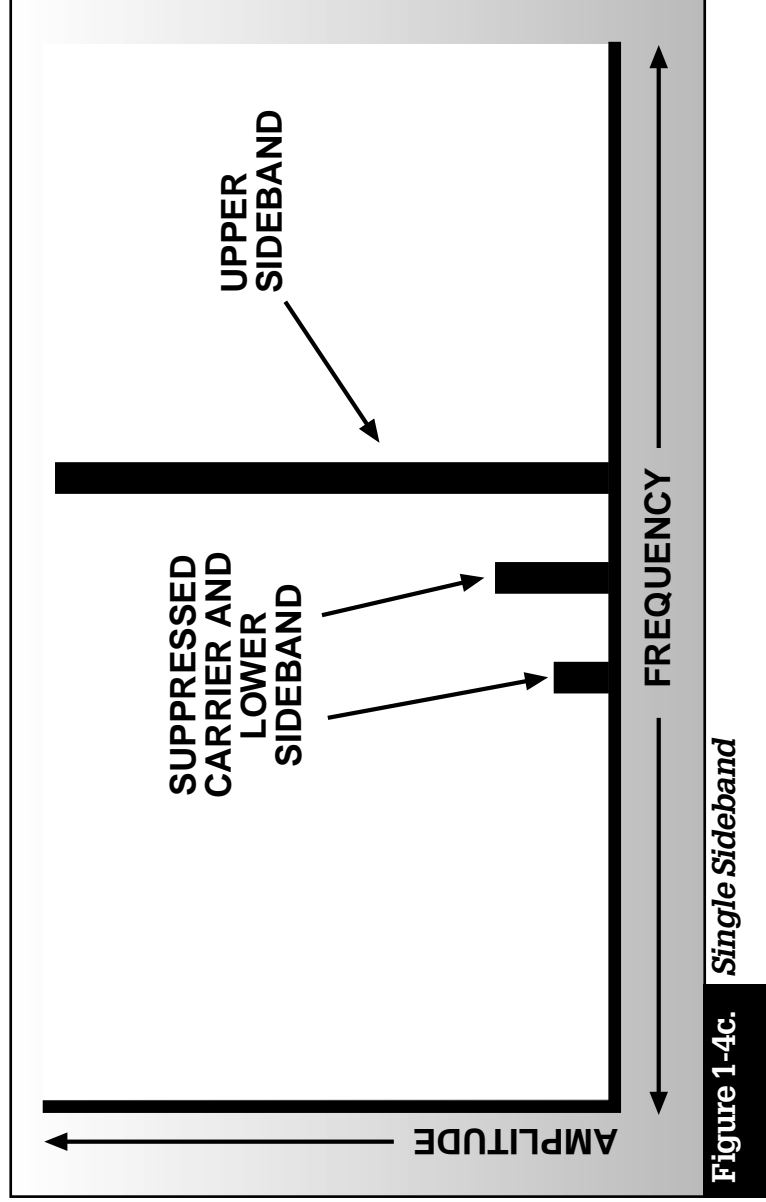
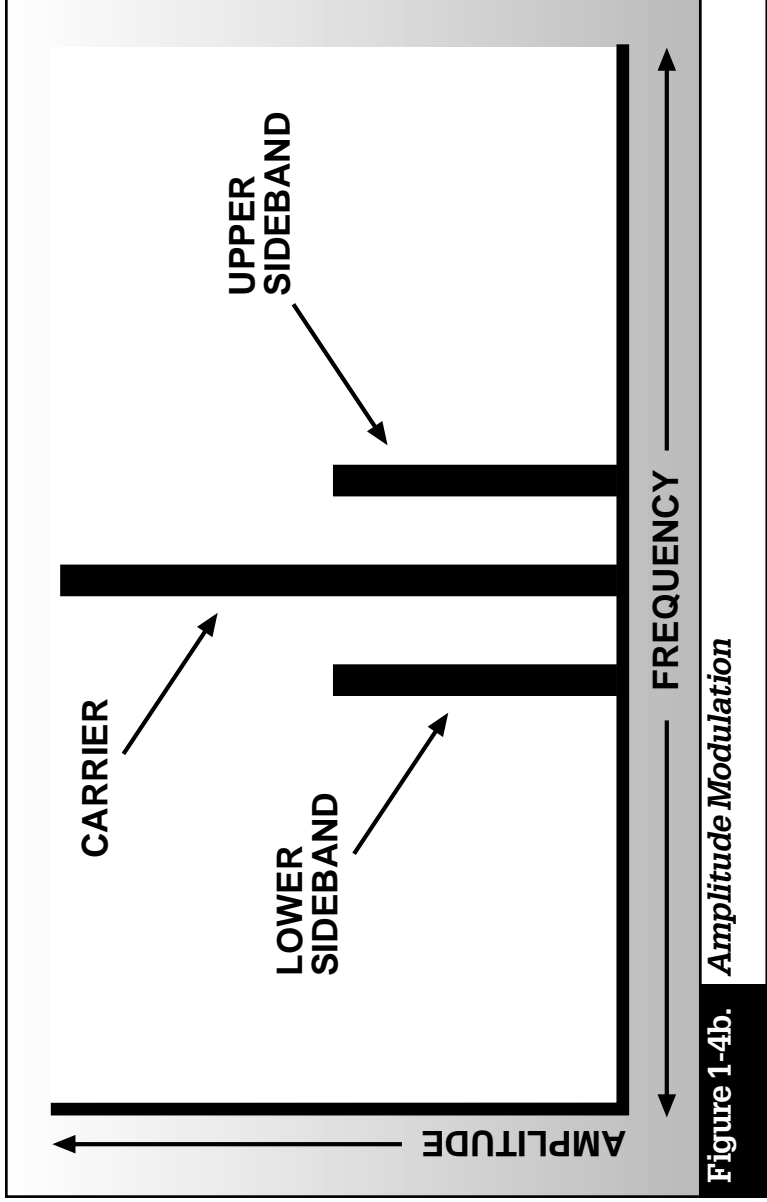

Figure 1-4a. *Amplitude Modulation*



One variation on this scheme, often used by military and commercial communicators, is amplitude modulation equivalent (*AME*), in which a carrier at a reduced level is transmitted with the sideband. *AME* lets one use a relatively simple receiver to detect the signal. Another important variation is independent sideband (*ISB*), in which both an upper and lower sideband, each carrying different information, are transmitted. This way, for example, one sideband can carry a data signal and the other can carry a voice signal.

Frequency modulation (*FM*) is a technique in which the carrier's frequency varies in response to changes in the modulating signal. For a variety of technical reasons, conventional *FM* generally produces a cleaner signal than *AM*, but uses much more bandwidth than *AM*. Narrowband *FM*, which is sometimes used in *HF* radio, provides an improvement in bandwidth utilization, but only at the cost of signal quality.

Other schemes support the transmission of data over *HF* channels, including shifting the frequency or phase of the signal. We will cover these techniques in Chapter 5.

Radio Wave Propagation

Propagation describes how radio signals radiate outward from a transmitting source. The action is simple to imagine for radio waves that travel in a straight line (picture that stone tossed into the still lake). The true path radio waves take, however, is often more complex.

There are two basic modes of propagation: *ground waves* and *sky waves*. As their names imply, ground waves travel along the surface of the earth, while sky waves “bounce” back to earth. Figure 1-5 shows the different propagation paths for *HF* radio waves.

Ground waves consist of three components: *surface waves*, *direct waves*, and *ground-reflected waves*.

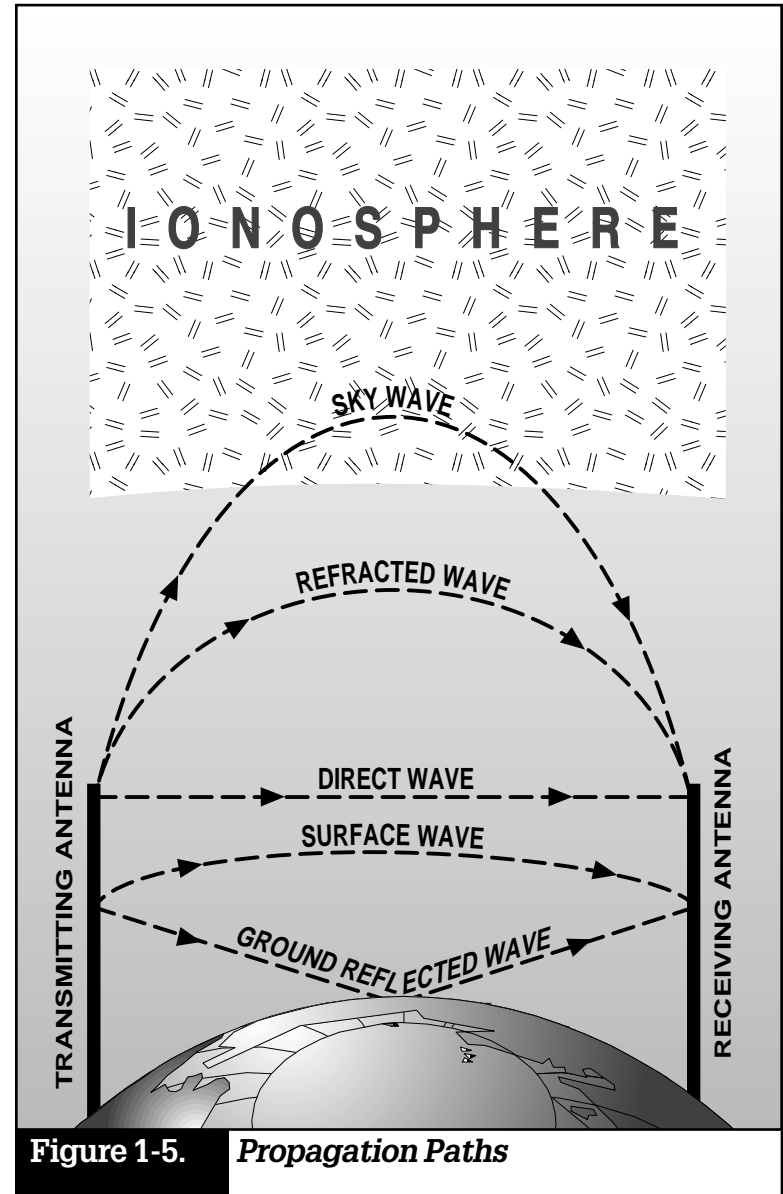

Figure 1-5. Propagation Paths

Surface waves travel along the surface of the earth, reaching beyond the horizon. Eventually, surface wave energy is absorbed by the earth. The effective range of surface waves is largely determined by the frequency and conductivity of the surface over which the waves travel. Absorption increases with frequency.

Transmitted radio signals, which use a carrier traveling as a surface wave, are dependent on transmitter power, receiver sensitivity, antenna characteristics, and the type of path traveled. For a given complement of equipment, the range may extend from 200 to 250 miles over a conductive, all-sea-water path. Over arid, rocky, non-conductive terrain, however, the range may drop to less than 20 miles, even with the same equipment.

Direct waves travel in a straight line, becoming weaker as distance increases. They may be bent, or *refracted*, by the atmosphere, which extends their useful range slightly beyond the horizon. Transmitting and receiving antennas must be able to “see” each other for communications to take place, so antenna height is critical in determining range. Because of this, direct waves are sometimes known as line-of-sight (*LOS*) waves.

Ground-reflected waves are the portion of the propagated wave that is reflected from the surface of the earth between the transmitter and receiver.

Sky waves make beyond line-of-sight (*BLOS*) communications possible. At certain frequencies, radio waves are refracted (or bent), returning to earth hundreds or thousands of miles away. Depending on frequency, time of day, and atmospheric conditions, a signal can bounce several times before reaching a receiver.

Using sky waves can be tricky, since the ionosphere is constantly changing. In the next chapter, we’ll discuss sky waves in greater detail.

SUMMARY

- Radio signals propagate from a transmitting antenna as waves through space at the speed of light.
- Radio frequency is expressed in terms of hertz (cycles per second), kilohertz (thousands of hertz), or megahertz (millions of hertz).
- Frequency determines the length of a radio wave; lower frequencies have longer wavelengths and higher frequencies have shorter wavelengths.
- Long-range radio communications take place in the high-frequency (HF) range of 1.6 to 30 MHz. Different portions of this band are allocated to specific radio services under international agreement.
- Modulation is the process whereby the phase, amplitude, or frequency of a carrier signal is modified to convey intelligence.
- HF radio waves can propagate as sky waves, which are refracted from the earth's ionosphere, permitting communications over long distances.

THE IONOSPHERE AND HF RADIO PROPAGATION

To understand sky wave propagation, you need to consider the effects of the *ionosphere* and solar activity on HF radio propagation. You must also be familiar with the techniques used to predict propagation and select the best frequencies for a particular link at a given time. Let's start with some definitions.

The Ionosphere, Nature's Satellite

The ionosphere is a region of electrically charged particles or gases in the earth's atmosphere, extending from approximately 50 to 600 km (30 to 375 miles) above the earth's surface. Ionization, the process in which electrons are stripped from atoms and produces electrically charged particles, results from solar radiation. When the ionosphere becomes heavily ionized, the gases may even glow and be visible. This phenomenon is known as Northern and Southern Lights.

Why is the ionosphere important in HF radio? Well, this blanket of gases is like nature's satellite, actually making most BLOS radio communications possible. When radio waves strike these ionized layers, depending on frequency, some are completely absorbed, others are refracted so that they return to the earth, and still others pass through the ionosphere into outer space. Absorption tends to be greater at lower frequencies, and increases as the degree of ionization increases.

The angle at which sky waves enter the ionosphere is known as the *incident angle* (Figure 2-1). This is determined by wavelength and the type of transmitting antenna. Like a billiard ball bouncing off a rail, a radio wave reflects from the ionosphere at the same angle it hits it. Thus, the incident angle is an important factor in determining communications range. If you need to reach a station that is relatively far from you, you would want the incident angle to be relatively large. To communicate with a nearby station, the incident angle should be relatively small.

The incident angle of a radio wave is critical, because if it is too nearly vertical, it will pass through the ionosphere without being refracted back to earth. If the angle is too great, the waves will be absorbed by the lower layers before reaching the more densely ionized upper layers. So, incident angle must be sufficient for bringing the radio wave back to earth yet not so great that it will lead to absorption.

Layers of the Ionosphere

Within the ionosphere, there are four layers of varying ionization (Figure 2-2). Since ionization is caused by solar radiation, the higher layers of the ionosphere tend to be more dense, while the lower layers, protected by the outer layers, experience less ionization. Of these layers, the first, discovered in the early 1920s by Appleton, was designated E for electric waves. Later, D and F were discovered and noted by these letters. Additional ionospheric phenomena were discovered through the 1930s and 1940s, such as sporadic E and aurora. A, B, and C are still available for further discoveries.

In the ionosphere, *the D layer* is the lowest region affecting HF radio waves. Ionized only during the day, the D layer reaches maximum ionization when the sun is at its zenith and dissipates quickly toward sunset.

The *E layer* reaches maximum ionization at noon. It begins dissipating toward sunset and reaches minimum activity at

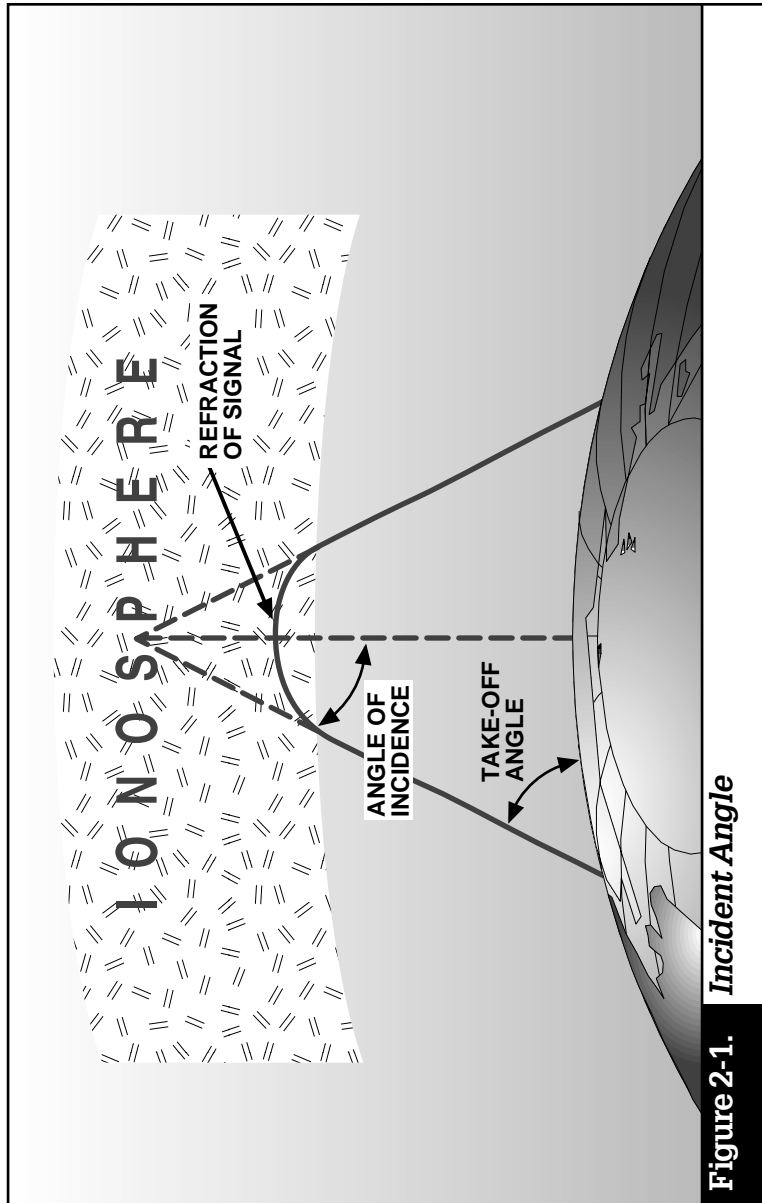

Figure 2-1. Incident Angle

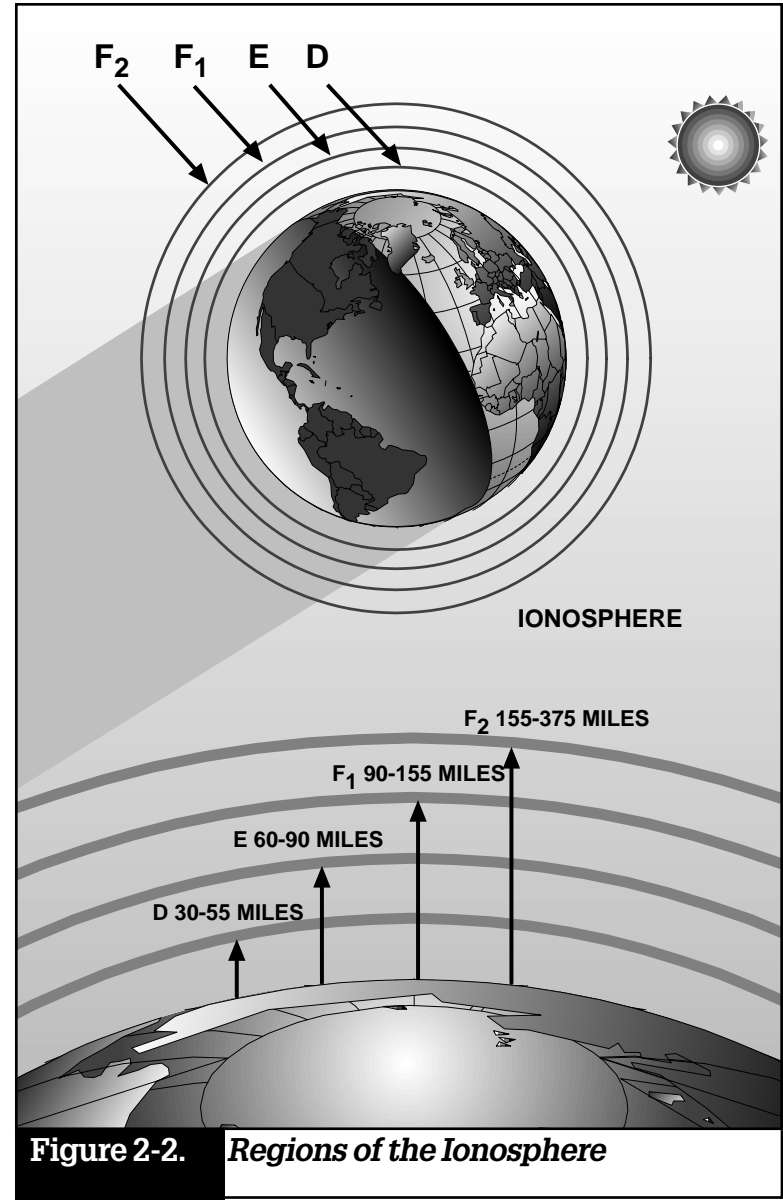

Figure 2-2. Regions of the Ionosphere

midnight. Irregular cloud-like formations of ionized gases occasionally occur in the E layer. These regions, known as *sporadic E*, can support propagation of sky waves at the upper end of the HF band and beyond.

The most heavily ionized region of the ionosphere, and therefore the most important for long-haul communications, is the *F layer*. At this altitude, the air is thin enough that the ions and electrons recombine very slowly, so the layer retains its ionized properties even after sunset.

In the daytime, the F layer consists of two distinct layers, F_1 and F_2 . The F_1 layer, which exists only in the daytime and is negligible in winter, is not important to HF communications. The F_2 layer reaches maximum ionization at noon and remains charged at night, gradually decreasing to a minimum just before sunrise.

During the day, sky wave reflection from the F_2 layer requires wavelengths short enough to penetrate the ionized D and E layers, but not so short as to pass through the F layer. Generally, frequencies from 10 to 20 MHz will accomplish this, but the same frequencies used at night would penetrate the F layer and pass into outer space. The most effective frequencies for long-haul nighttime communications are normally between 3 and 8 MHz.

Factors Affecting Atmospheric Ionization

The intensity of solar radiation and therefore ionization varies periodically. Hence, we can predict solar radiation intensity based on time of day and the season, for example, and make adjustments in equipment to limit or optimize ionization effects.

Ionization is higher during spring and summer because the hours of daylight are longer. Sky waves are absorbed or weakened as they pass through the highly charged D and E layers, reducing, in effect, the communication range of most HF bands.

Because there are fewer hours of daylight during autumn and winter, less radiation reaches the D and E layers. Lower frequencies pass easily through these weakly ionized layers. Therefore, signals arriving at the F layer are stronger and are reflected over greater distances.

Another longer term periodic variation results from the 11-year *sunspot cycle* (Figure 2-3). Sunspots generate bursts of radiation that cause higher levels of ionization. The more sunspots, the greater the ionization. During periods of low sunspot activity, frequencies above 20 MHz tend to be unusable because the E and F layers are too weakly ionized to reflect signals back to earth. At the peak of the sunspot cycle, however, it is not unusual to have worldwide propagation on frequencies above 30 MHz.

In addition to these regular variations, there is a class of unpredictable phenomena known as sudden ionospheric disturbances (*SID*), which can affect HF communications as well. SIDs, random events due to solar flares, can disrupt sky wave communication for hours or days at a time. Solar flares produce intense ionization of the D layer, causing it to absorb most HF signals on the side of the earth facing the sun.

Magnetic storms often follow the eruption of solar flares within 20 to 40 hours. Charged particles from the storms have a scattering effect on the F layer, temporarily neutralizing its reflective properties.

Frequency and Path Optimization

Because ionospheric conditions affect radio wave propagation, communicators must determine the best way to optimize radio frequencies at a particular time. The highest possible frequency that can be used to transmit over a particular path under given ionospheric conditions is called the Maximum Usable Frequency (*MUF*). Frequencies higher than the MUF penetrate the ionosphere and continue into space. Frequencies lower than the MUF tend to refract back to earth.

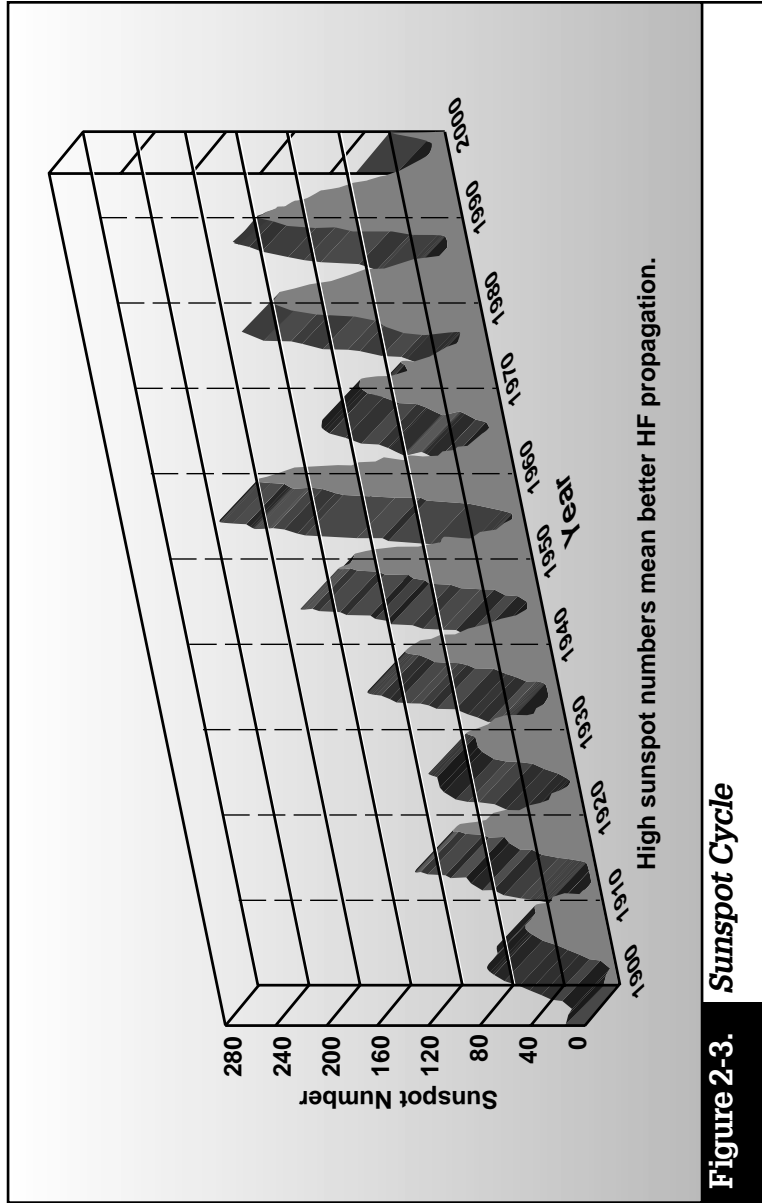

As frequency is reduced, the amount of absorption of the signal by the D layer increases. Eventually, the signal is completely absorbed by the ionosphere. The frequency at which this occurs is called the Lowest Usable Frequency (*LUF*). The “window” of usable frequencies, therefore, lies between the MUF and LUF.

The Frequency of Optimum Transmission (*FOT*) is nominally 85 percent of the MUF. Generally, the FOT is lower at night and higher during the day. These frequencies are illustrated in Figure 2-4.

In addition to frequency, the route the radio signal travels must also be considered in optimizing communications. A received signal may be comprised of components arriving via several routes, including one or more sky wave paths and a ground wave path. The arrival times of these components differ because of differences in path length; the range of time differences is the *multipath spread*. The effects of multipath spread can be minimized by selecting a frequency as close as possible to the MUF.

Propagation Prediction Techniques

Since many of the variables affecting propagation follow repetitive cycles and can be predicted, techniques for effectively determining FOT have been developed.

A number of propagation prediction computer programs are available. One widely used and effective program is Ionospheric Communications Analysis and Prediction (*IONCAP*), which predicts system performance at given times of day as a function of frequency for a given HF path and a specified complement of equipment.

Of course, since computerized prediction methods are based on historic data, they cannot account for present conditions affecting communications, like ionospheric changes caused by random phenomena such as interference and noise (more about these later).

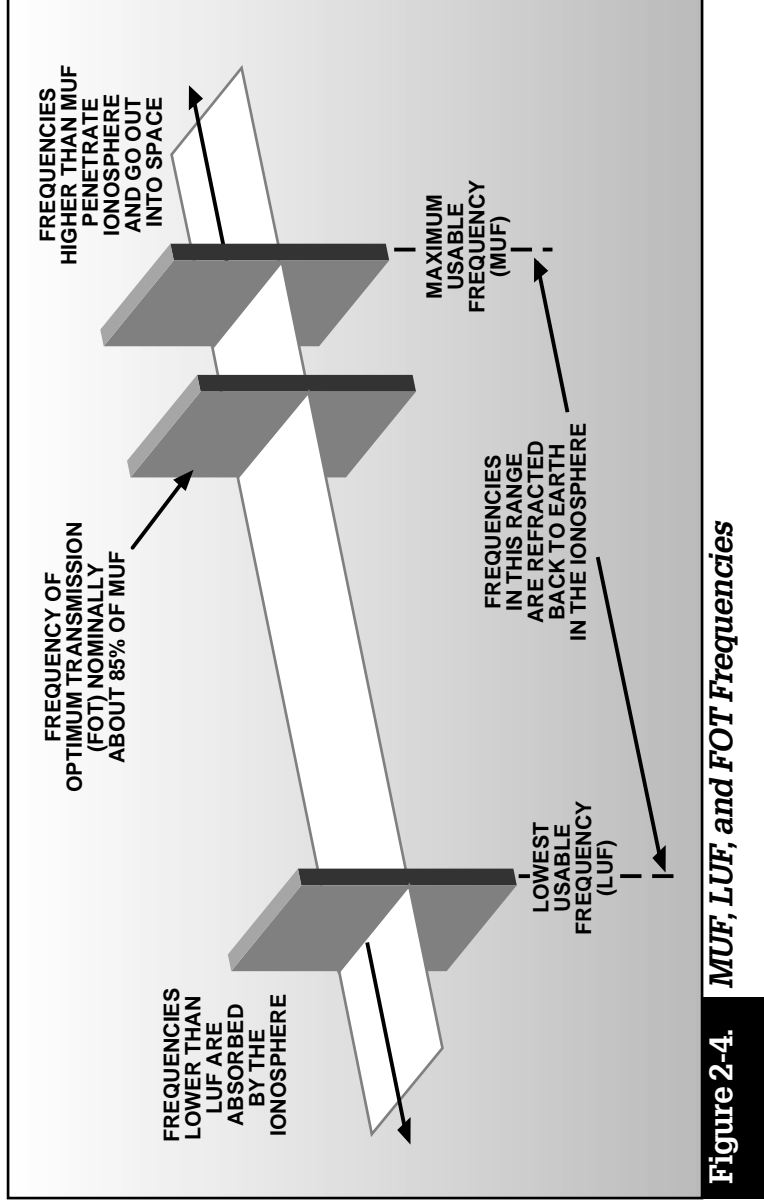

A more immediate automated prediction method involves *ionospheric sounding*. One system, the Chirpsounder™, uses remote stations to transmit test signals (chirps) that sweep through all frequencies from 2 to 30 MHz. The receiver tracks the signal, analyzes its reception on assigned operating frequencies, and displays frequency ranges for optimum propagation.

In addition, modern HF communications systems are increasingly making use of Link Quality Analysis (*LQA*) techniques. In these systems, transmitting and receiving stations cooperate to assess automatically the quality of the channels available to them. When the need to communicate arises, the LQA data is used to select the best frequency. We'll take a closer look at this technique in Chapter 6.

SUMMARY

- The ionosphere is a region of electrically charged particles or gases in the earth's atmosphere, extending from 50 to 600 km (approximately 30 to 375 miles) above the earth's surface.
- There are layers of varying electron density in the ionosphere that absorb, pass, or reflect radio waves, depending on the density of the layer, the angle with which the radio waves strike it, and the frequency of the signal.
- Ionization, caused by solar radiation, strips electrons from atoms, producing electrically charged particles.
- The density of ionospheric layers varies with the intensity of solar radiation, which changes according to time of day, season, and sunspot cycle.
- The angle of radiation is determined by the wavelength of a signal and the type of antenna used.
- Radio waves are absorbed as they pass through the ionosphere. The absorption rate increases as frequency decreases.
- Communications is best at the frequency of optimum transmission (FOT), nominally 85 percent of the maximum usable frequency (MUF).
- Sunspots increase and decrease in 11-year cycles. Higher sunspot numbers increase ionization, lower sunspot numbers cause less ionization.
- Solar flares cause sudden ionospheric disturbances (SIDs), which can disrupt HF communications.
- Propagation prediction techniques, such as IONCAP, determine the MUF, LUF, and FOT for a given transmission path and time of day. Other methods include ionospheric sounding and Link Quality Analysis (LOA).

ELEMENTS IN AN HF RADIO SYSTEM

Now that you have an overview of how radio waves propagate, let's take a look at how they are generated. The primary components in an HF radio system fall into three groups: transmitters, receivers, and antennas. In many modern radio sets, the transmitter and receiver are contained in a single unit called a *transceiver*. In large, fixed systems, transmitting stations and receiving stations are customarily at separate locations, often controlled from a remote third site.

Transmitter Group

Although transmitters may vary widely in their configuration, they all consist of an *exciter* and *power amplifier*. A simplified diagram of a typical HF transmitter is shown in Figure 3-1.

The exciter synthesizes a carrier, which has one of its properties — amplitude, frequency, or phase — modified (modulated) by a lower frequency signal derived from a source of information such as a microphone. The resulting signal is converted to the frequency that is to be transmitted. The power amplifier boosts the output power of the signal to the desired wattage for transmission before sending it through a cable to the transmitting antenna.

The transmitter may also contain filters that are used to “clean up” its output. A *bandpass filter* removes noise, spurious signals, and harmonics generated in the exciter, or output frequency

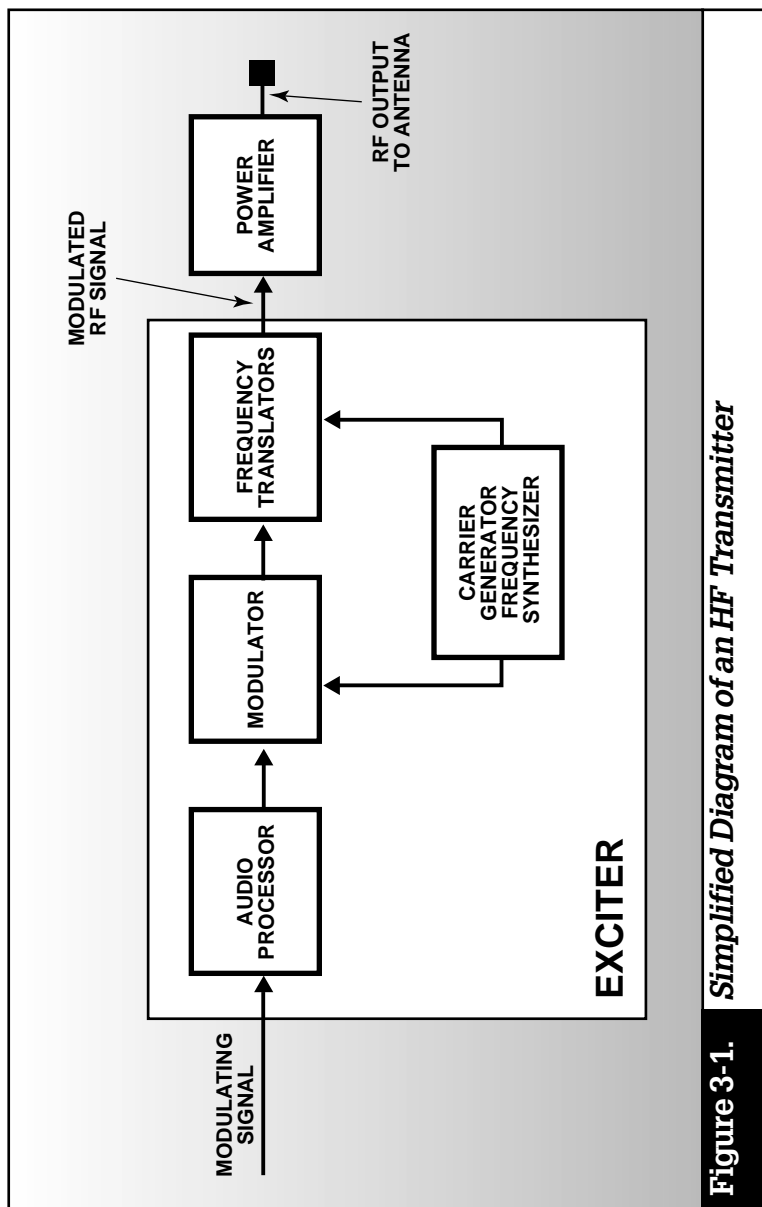

Figure 3-1. Simplified Diagram of an HF Transmitter

harmonics coming from the power amplifier. This process reduces interference with adjacent communications channels.

Receiver Group

All modern HF receiving systems include an RF input filter/ amplifier, a series of frequency converters and intermediate frequency (IF) amplifiers, a demodulator, and a local oscillator frequency synthesizer (see Figure 3-2). To function, the receiver selects a desired signal, amplifies it to a suitable level, and recovers the information through the process of *demodulation*, in which the original modulating signal is recovered from a modulating carrier. With contemporary radio equipment, many of these functions are performed digitally.

In order to filter out noise and undesired signals, the RF input stage sometimes incorporates a tunable preselector (a bandpass filter). The filtered signal is then amplified and converted to another frequency for further processing.

But the filtering process does not end here. Typically, the received signal is filtered and amplified again at several different intermediate frequencies. The amplification provided in these stages is a variable that depends on the strength of the received signal.

In order to output voice or data, for example, the demodulator produces an audio-frequency (*baseband*) signal that interfaces with additional equipment. Also, because the strength of the input signal may not be constant, the demodulator stage produces a voltage proportional to the level of the RF input signal. To compensate for changes in the signal, the voltage is fed back to the RF and IF amplifiers for automatic gain control (*AGC*), to maintain a constant input to the demodulator.

The Antenna Group

The antenna is one of the most critical elements in a radio circuit. Here, we will look at typical antenna types and their applications.

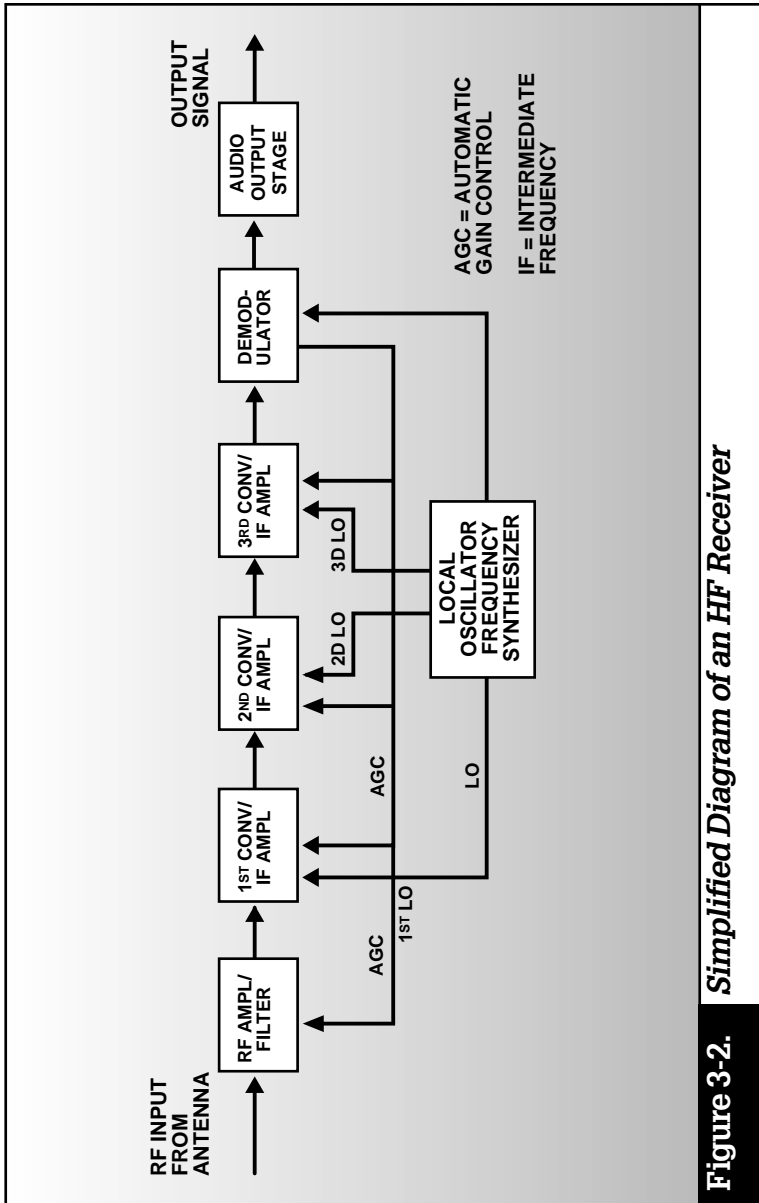

Figure 3-2. Simplified Diagram of an HF Receiver

Antenna Characteristics and Parameters

Some of the most commonly used terms to describe antennas are *impedance*, *gain*, *radiation pattern*, *take-off angle*, and *polarization*.

Every antenna has an input impedance, which represents the load to be applied to the transmitter. This impedance depends upon many factors, such as antenna design, frequency of operation, and location of the antenna with respect to surrounding objects.

The basic challenge in radio communications is finding ways to get the most power possible, where and when you need it, to generate and transmit signals. Most transmitters are designed to provide maximum output power and efficiency into a 50-ohm load. (*OHM* is a unit of measurement of resistance. Its symbol is Ω .) Some antennas, such as log periodic antennas, can provide a 50-ohm load to the transmitter over a wide range of frequencies. These antennas can generally be connected directly to the transmitter. Other antennas, such as dipoles, whips, and long-wire antennas, have impedances that vary widely with frequency and the surrounding environment. In these cases, an *antenna tuner* or *coupler* is used. This device is inserted between the transmitter and antenna to modify the characteristics of the load presented to the transmitter so that maximum power may be transferred from the transmitter to the antenna.

The *gain* of an antenna is a measure of its directivity — its ability to focus the energy it radiates in a particular direction. The gain may be determined by comparing the level of signal received from it against the level that would be received from an isotropic antenna, which radiates equally in all directions. Gain can be expressed in dBi; the higher this number, the greater the directivity of the antenna. Transmitting antenna gain directly affects transmitter power requirements. If, for example, an omnidirectional antenna were replaced by a directional antenna with a gain of 10 dBi, a 100-watt transmitter would produce the same effective radiated power as a 1-kW transmitter and omnidirectional antenna.

In addition to gain, radio users must understand the radiation pattern of an antenna for optimal signal transmission. Radiation pattern is determined by an antenna's design and is strongly influenced by its location with respect to the ground. It may also be affected by its proximity to nearby objects such as buildings and trees. In most antennas, the pattern is not uniform, but is characterized by lobes (areas of strong radiation) and nulls (areas of weak radiation). These patterns are generally represented graphically in terms of plots in the vertical and horizontal planes (Figure 3-3), which show antenna gain as a function of elevation angle (vertical pattern) and azimuth angle (horizontal plot). The radiation patterns are frequency dependent, so plots at different frequencies are required to fully characterize the radiation pattern of an antenna.

In determining communications range, it is important to factor in the *take-off angle*, which is the angle between the *main lobe* of an antenna pattern and the horizontal plane of the transmitting antenna. Low take-off angles are generally used for long-haul communications; high take-off angles are used for shorter-range communications.

The orientation of an antenna with respect to the ground determines its *polarization*. Most HF antennas are either vertically or horizontally polarized. A vertically polarized antenna produces low take-off angles and is therefore suitable for ground waves and for long-haul sky wave links. The main drawback of vertical antennas is their sensitivity to ground conductivity and locally generated noise. It is necessary to use a grounding screen to get the best results.

A horizontally polarized antenna radiates at higher take-off angles and is suitable for shorter range communications, out to about 400 miles. By adjusting the height of the antenna above ground, it is possible to increase gain at lower take-off angles for longer-range sky wave performance. Horizontally polarized antennas are largely independent of ground conductivity, and are less affected by local noise than vertical antennas.

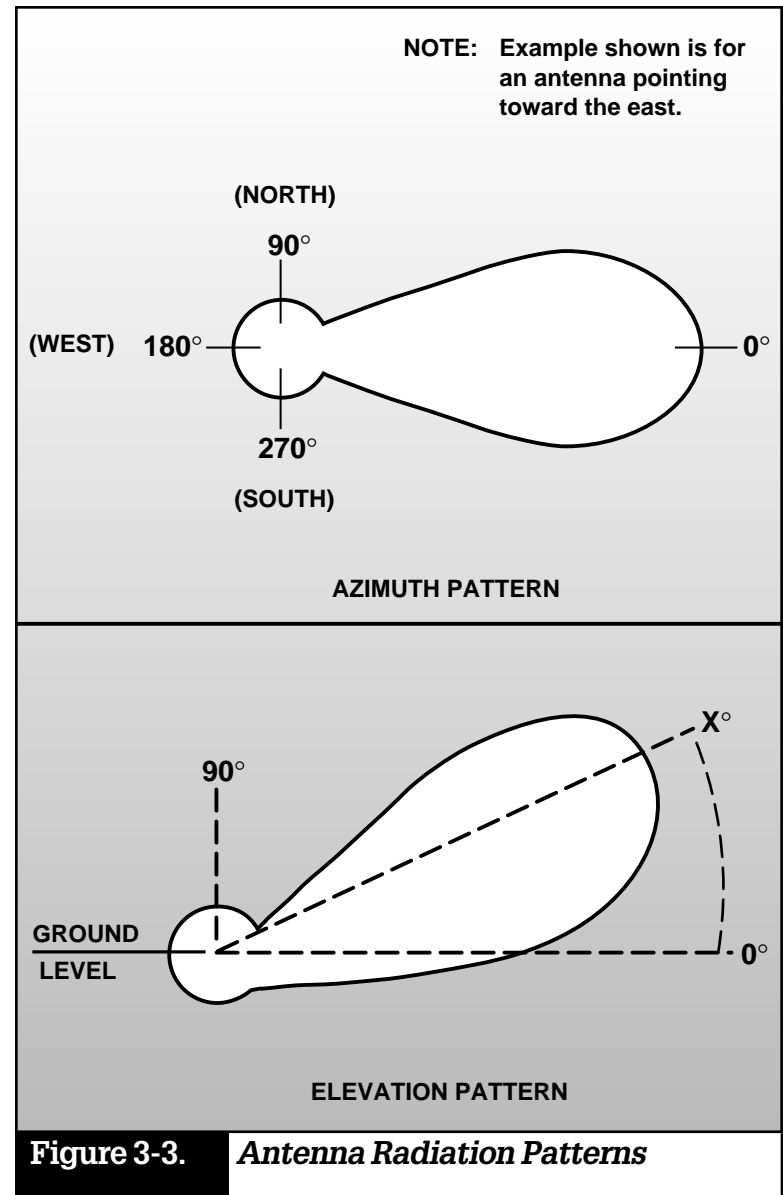

For ground wave propagation, the transmitting and receiving antennas should have the same polarization for best results. For sky wave propagation, the polarization of the antennas need not be the same, since the polarization of the signal will change during ionospheric refraction.

Types of Antennas

There is a countless variety of antennas used in HF communication. We'll focus here on just some of the more common types.

The *vertical whip* antenna is usually adequate for ground wave circuits, since it is *omnidirectional*, has low take-off angles, and is vertically polarized. A typical vertical whip radiation pattern is shown in Figure 3-4. A reflector, consisting of a second vertical whip, can add directivity to the radiation pattern of a whip.

One of the most versatile types of HF antenna is the half-wave *dipole*, which is basically a length of wire equal to one-half the transmitting wavelength. The dipole can be oriented to provide either horizontal or vertical (center-fed) polarization. Figure 3-5 shows a center-fed horizontal dipole antenna. The radiation pattern can change dramatically as a function of its distance above the ground. Figure 3-6 shows the vertical radiation pattern of a horizontal dipole for several values of its height (in terms of transmitting wavelength) above the ground.

A vertical dipole can often be used effectively on ships or vehicles. An inverted vee (sometimes called a "drooping dipole") produces a combination of horizontal and vertical radiation with omnidirectional coverage. See Figure 3-7.

Directional antennas range from simple single-wire configurations like the inverted vee to elaborate multi-wire arrays, including horizontal and vertical log periodic systems; see Figure 3-8. Directional antennas are often used in point-to-point links. In systems requiring point-to-point communications to widely dispersed stations, rotatable directional antennas may be used.

Sky wave communications between relatively closely spaced stations may require antennas specially designed for this purpose. These near vertical incidence sky wave (NVIS) antennas have a very high take-off angle, radiating RF energy nearly straight up. The radio waves refract downward to the earth in a circular pattern. NVIS antennas provide omnidirectional coverage out to about 600 km.

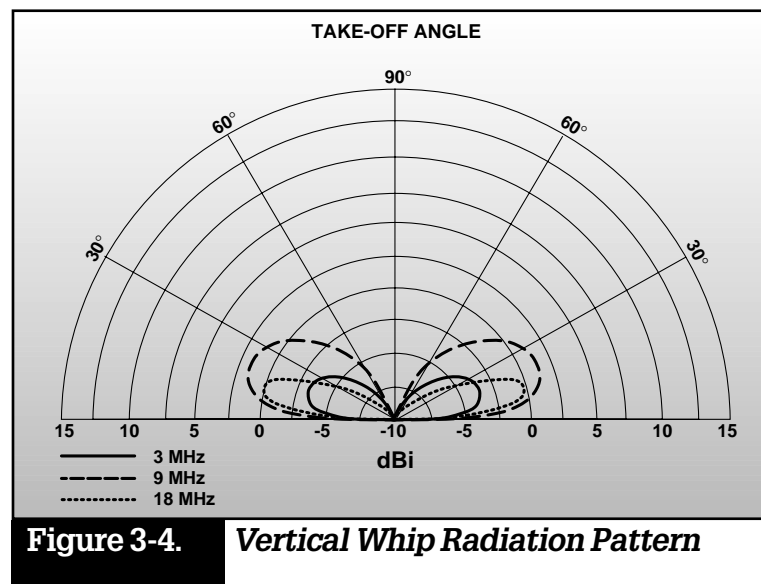
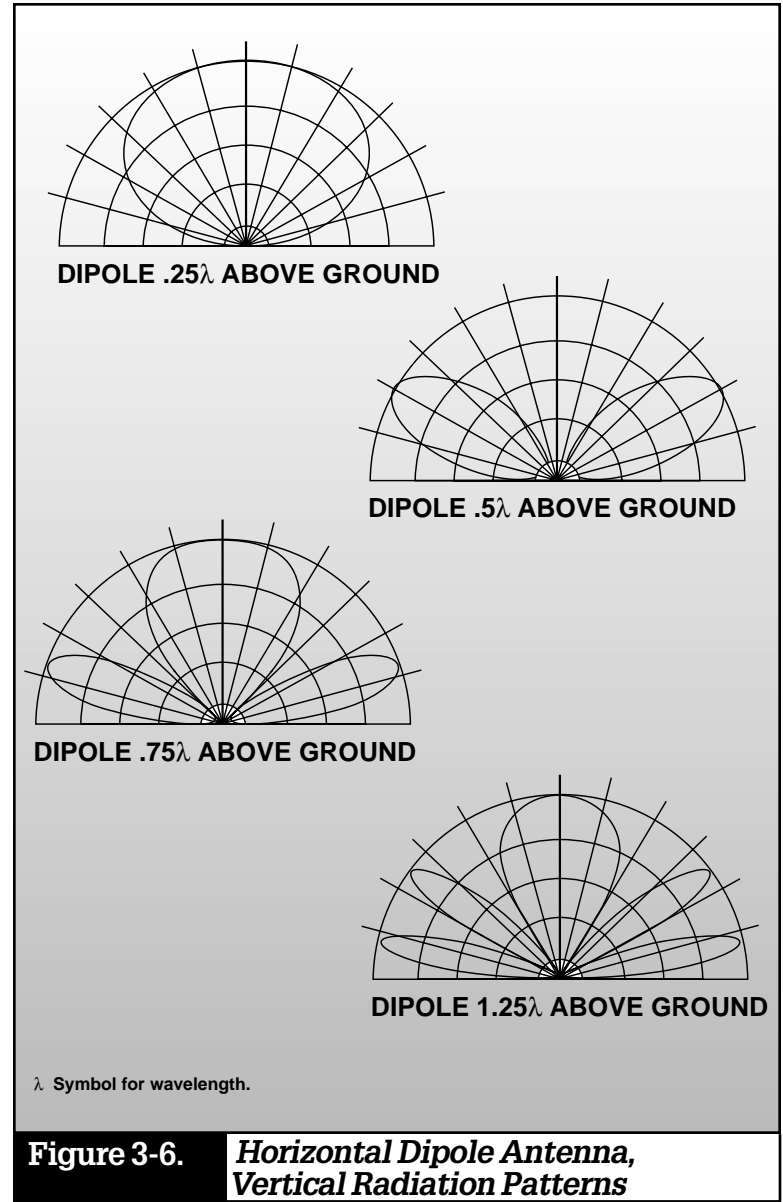
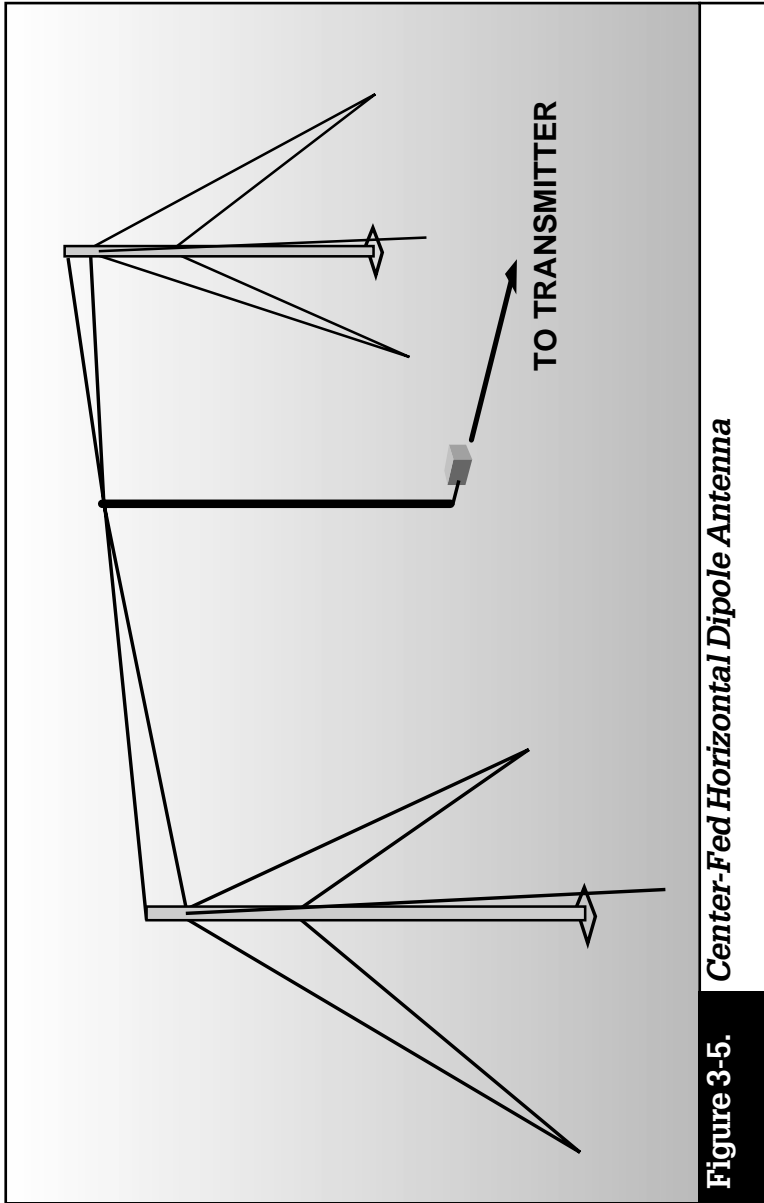
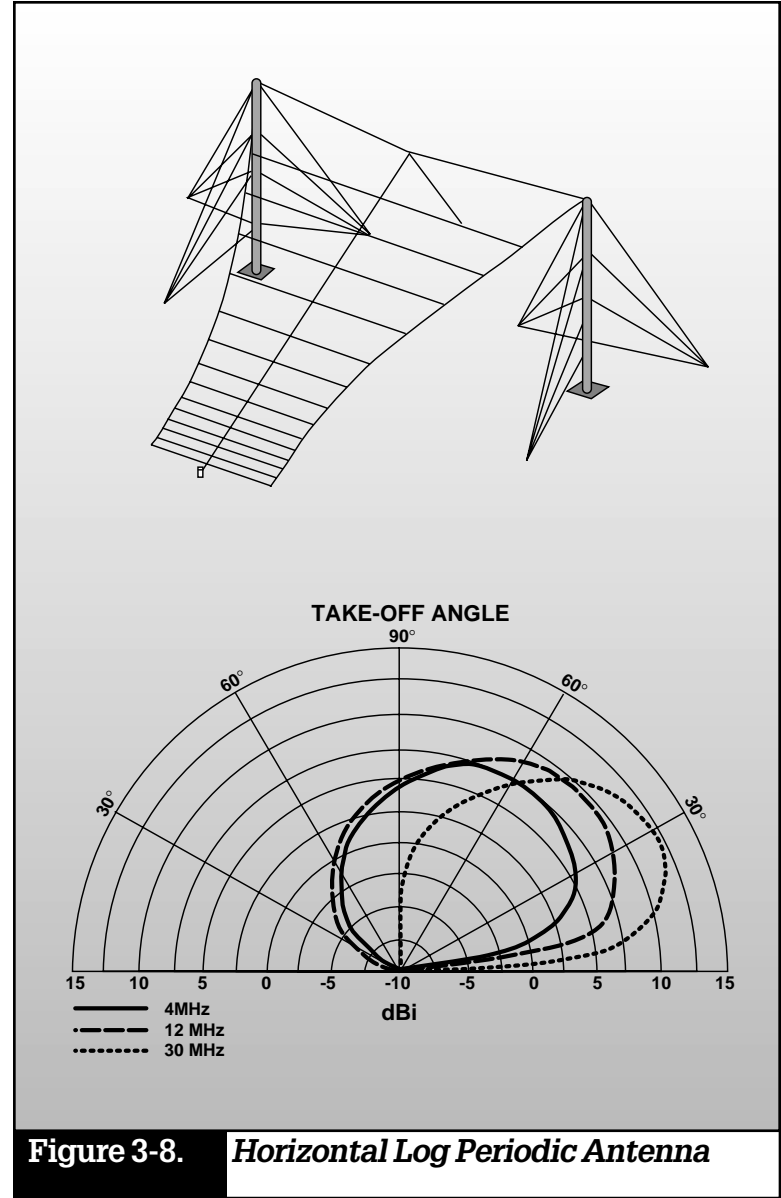
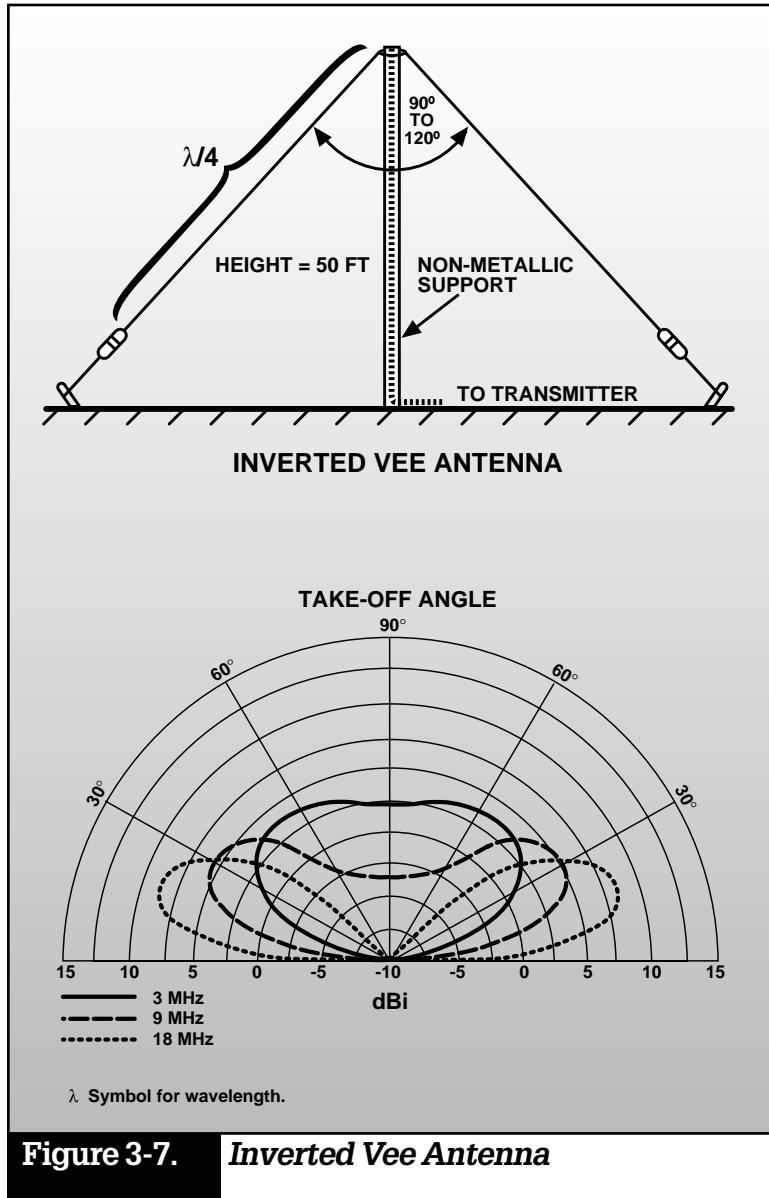

Figure 3-4. Vertical Whip Radiation Pattern





SUMMARY

- A radio system consists of a transmitter, receiver, and antenna group.
- The transmitter group consists of an exciter and power amplifier. The exciter includes a modulator, carrier generator, and frequency translator.
- The receiver group consists of an RF input filter/amplifier, frequency converters/IF amplifiers, demodulator, and local oscillator.
- Antenna selection is critical to successful HF communications. Antenna types include vertical whip, dipole, and directional.
- An antenna coupler matches the impedance of the antenna to that of the transmitter, transferring maximum power to the antenna.
- The gain of an antenna is a measure of its directivity — its ability to focus the energy it radiates in a particular direction.
- Antenna radiation patterns are characterized by nulls (areas of weak radiation) and lobes (areas of strong radiation).
- Low antenna take-off angles are generally used for long-haul communications; high take-off angles are used for shorter-range communications.

NOISE AND INTERFERENCE

While listening to the radio during a thunderstorm, you're sure to have noticed interruptions or static at one time or another. Perhaps you heard the voice of a pilot rattling off data to a control tower when you were listening to your favorite FM station. This is an example of interference that is affecting a receiver's performance. Annoying as this may be while you're trying to listen to music, noise and interference can be hazardous in the world of HF communications, where a mission's success or failure depends on hearing and understanding the transmitted message.

Receiver noise and interference come from both external and internal sources. External noise levels greatly exceed internal receiver noise over much of the HF band. Signal quality is indicated by signal-to-noise ratio (*SNR*), measured in decibels (*dB*). The higher the *SNR*, the better the signal quality. Interference may be inadvertent, as in the case of the pilot's call to the tower. Or, it may be a deliberate attempt on the part of an adversary to disrupt an operator's ability to communicate.

Engineers use various techniques to combat noise and interference, including: (1) boosting the effective radiated power, (2) providing a means for optimizing operating frequency, (3) choosing a suitable modulation scheme, (4) selecting the appropriate antenna system, and (5) designing receivers that reject interfering signals. Let's look at some of the more common causes of noise and interference.

Natural Sources of Noise

Lightning is the main atmospheric (natural) source of noise. *Atmospheric noise* is highest during the summer and greatest at night, especially in the 1- to 5-MHz range. Average values of atmospheric noise, as functions of time of day and season, have been determined for locations around the world, and are used in predicting HF radio system performance. Another natural noise source is galactic or *cosmic noise*, generated in space. It is uniformly distributed over the HF spectrum, but does not affect performance below 20 MHz.

Man-Made Noise

Power lines, computer equipment, and industrial and office machinery produce man-made noise, which can reach a receiver through radiation or by conduction through power cables. This type of man-made noise is called electromagnetic interference (*EMI*) and it is highest in urban areas. Grounding and shielding of the radio equipment and filtering of AC power input lines are techniques used by engineers to suppress EMI.

Unintentional Interference

At any given time, thousands of HF transmitters compete for space on the radio spectrum in a relatively narrow range of frequencies, causing interference with one another. Interference is most severe at night in the lower bands at frequencies close to the MUF. The HF radio spectrum is especially congested in Europe due to the density of the population.

A major source of unintentional interference is the *collocation* of transmitters, receivers, and antennas. It's a problem on ships, for instance, where space limitations dictate that several radio systems be located together. For more than 30 years, Harris RF Communications has designed and implemented high-quality integrated shipboard communications systems that eliminate problems caused by collocation. Ways to reduce collocation interference include carefully orienting antennas, using receivers that won't overload on strong, undesired signals, and using transmitters that are designed to minimize intermodulation.

Intentional Interference

Deliberate interference, or *jamming*, results from transmitting on operating frequencies with the intent to disrupt communications. Jamming can be directed at a single channel or be wide-band. It may be continuous (constant transmitting) or look-through (transmitting only when the signal to be jammed is present). Modern military radio systems use *spread-spectrum* techniques to overcome jamming and reduce the probability of detection or interception. Spread-spectrum techniques are techniques in which the modulated information is transmitted in a bandwidth considerably greater than the frequency content of the original information. We'll look at these techniques in Chapter 7.

Signals from a transmitter reach the receiver via multiple paths (Figure 4-1). This causes *fading*, a variation in average signal level because these signals may add or subtract from each other in a random way.

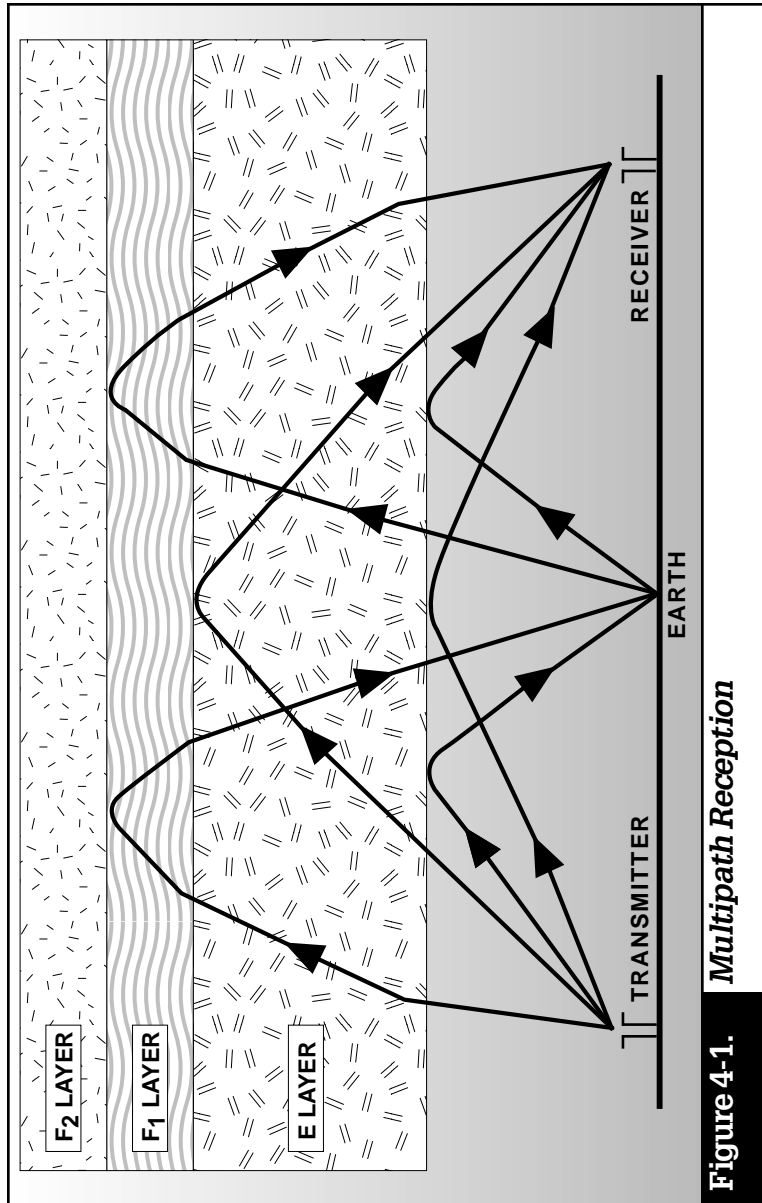

Figure 4-1. *Multipath Reception*

SUMMARY

- Natural (atmospheric) and man-made sources cause noise and interference. Lightning strikes are the primary cause of atmospheric noise; power lines, computer terminals, and industrial machinery are the primary cause of man-made noise.

- Congestion of HF transmitters competing for limited radio spectrum in a relatively narrow range of frequencies causes interference. It is generally worse at night in lower frequency bands.

- Collocated transmitters interfere with each other, as well as with nearby receivers.

- Jamming, or deliberate interference, results from transmitting on operating frequencies with the intent to disrupt communications.

- Multipath interference causes signal fading.

DATA COMMUNICATION VIA HF RADIO

From the very beginning, HF radio used Morse code for data communications. Over time, improved techniques were developed for data transmission that take into account the variability of the HF medium and greatly increase the speed at which data transmission occurs over a radio link. In addition, the application of error-correcting codes and automatic repeat request (ARQ) techniques offering error-free data transfer permits the use of HF radio in computer-to-computer communications systems.

To understand the principles of HF data communication, we'll define some common data terminology and explain the significance of the modem. We will also outline some of the problems and solutions associated with HF data communication.

Binary Data

Communication as an activity involves the transfer of information from a transmitter to a receiver over a suitable channel. Consider this book, for instance. It uses symbols (the alphabet) to encode information into a set of code groups (words) for transmission over a channel (the printed page) to a receiver (the reader). Applying this principle to data (information), we begin by using a kind of shorthand to transform the data into code words (*binary digits*, or *bits*) for transmission over a channel (HF radio) to a receiver (the reader).

Bits are part of a number system having a base of two that uses only the symbols 0 and 1. Thus, a bit is any variable that assumes two distinct states. For example, a switch is open or closed, a voltage is positive or negative, and so on.

A simple way to communicate binary data is to switch a circuit off and on in patterns that are interpreted at the other end of a link. This is essentially what was done in the early days of telegraphy. Later schemes used a bit to select one of two possible states of the properties that characterize a carrier (modulated radio wave) — either frequency or amplitude. More sophisticated approaches allow the carrier to assume more than two states and hence to represent multiple bits.

Baud Rate

Data transmission speed is commonly measured in bits per second (bps). Sometimes the word *baud* is used synonymously with bps, although the two terms actually have different meanings. Baud is a unit of signaling speed and is a measure of symbols per second that are being sent. A symbol may represent more than one bit.

The maximum baud rate that can be supported by a radio channel depends on its bandwidth — the greater the bandwidth, the greater the baud rate. The rate at which information is transmitted, the bit rate, depends on how many bits there are per symbol.

Asynchronous and Synchronous Data

The transmission of data occurs in either an *asynchronous* or a *synchronous* mode, as defined below.

In asynchronous data transmission, each character has a start and stop bit (Figure 5-1). The start bit prepares the data receiver to accept the character. The stop bit brings the data receiver back to an idle state.

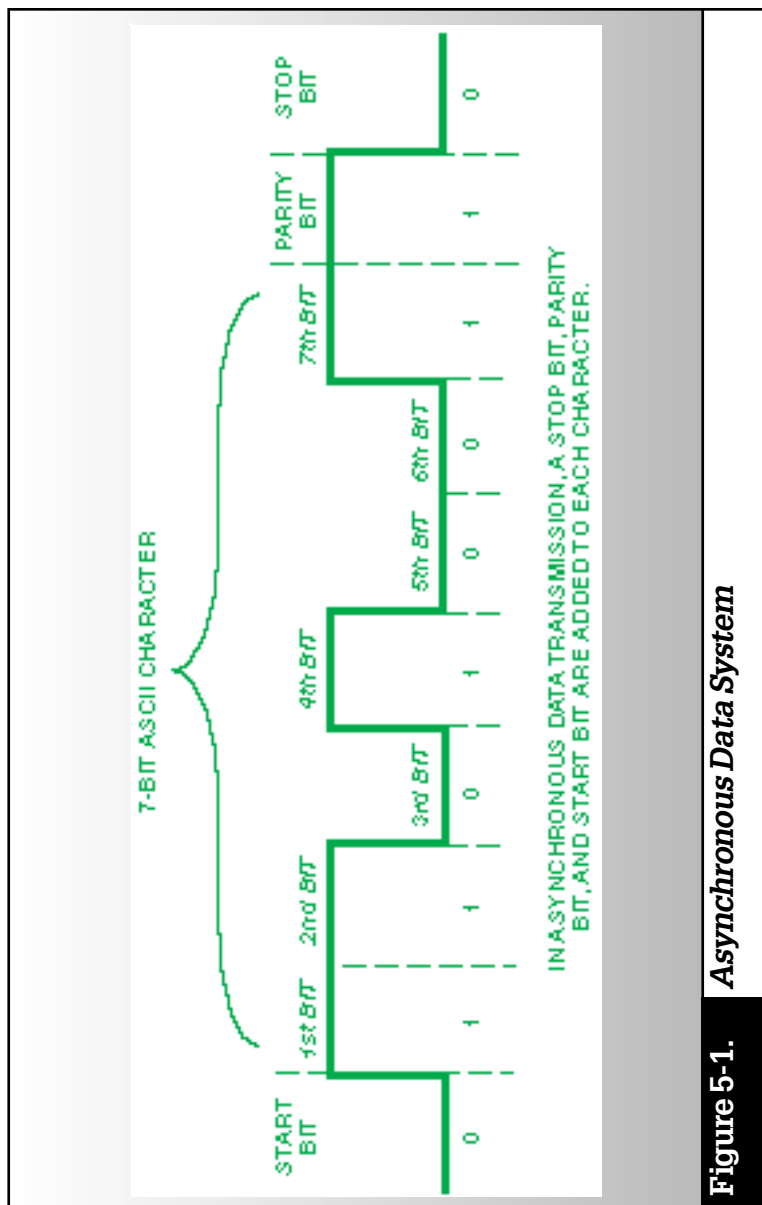

Asynchronous Data System

Figure 5-1.

Synchronous data transmission eliminates the start and stop bits. This type of system typically uses a *preamble* (a known sequence of bits, sent at the start of a message, that the receiver uses to synchronize to its internal clock) to alert the data receiver that a message is coming.

Asynchronous systems eliminate the need for complex synchronization circuits, but at the cost of higher overhead than synchronous systems. The stop and start bits increase the length of a character by 25 percent, from 8 to 10 bits.

HF Modems

A conventional voice radio cannot transmit data directly. Data digital voltage levels must be converted to audio, using a device called a *modulator*, which applies the audio to the transmitter. Conversely, at the receiver, a *demodulator* converts audio back to digital voltage levels. Harris' RF-5000 radios are equipped with built-in high-speed *modems* (the *MO*dulator and the *DE*Modulator, packaged together), which permit the radios to operate with either voice or data inputs.

HF modems fall into three basic categories: (1) modems with slow-speed frequency shift keying (*FSK*); (2) high-speed parallel tone modems; and (3) high-speed serial (single) tone modems.

The simplest modems employ FSK to encode binary data (0s and 1s) (see Figure 5-2). The input to the modulator is a digital signal that takes one of two possible voltage levels. The output of the modulator is an audio signal that is one of two possible tones. HF FSK systems are limited to data rates less than 75 bps due to the effects of multipath propagation. Higher rates are possible with multi-tone FSK (*MFSK*), which uses a greater number of frequencies.

High-speed HF modem technology, using both parallel and serial tone waveforms to allow transmission at up to 4800 bps, was pioneered by Harris in the early 1980s. The serial tone

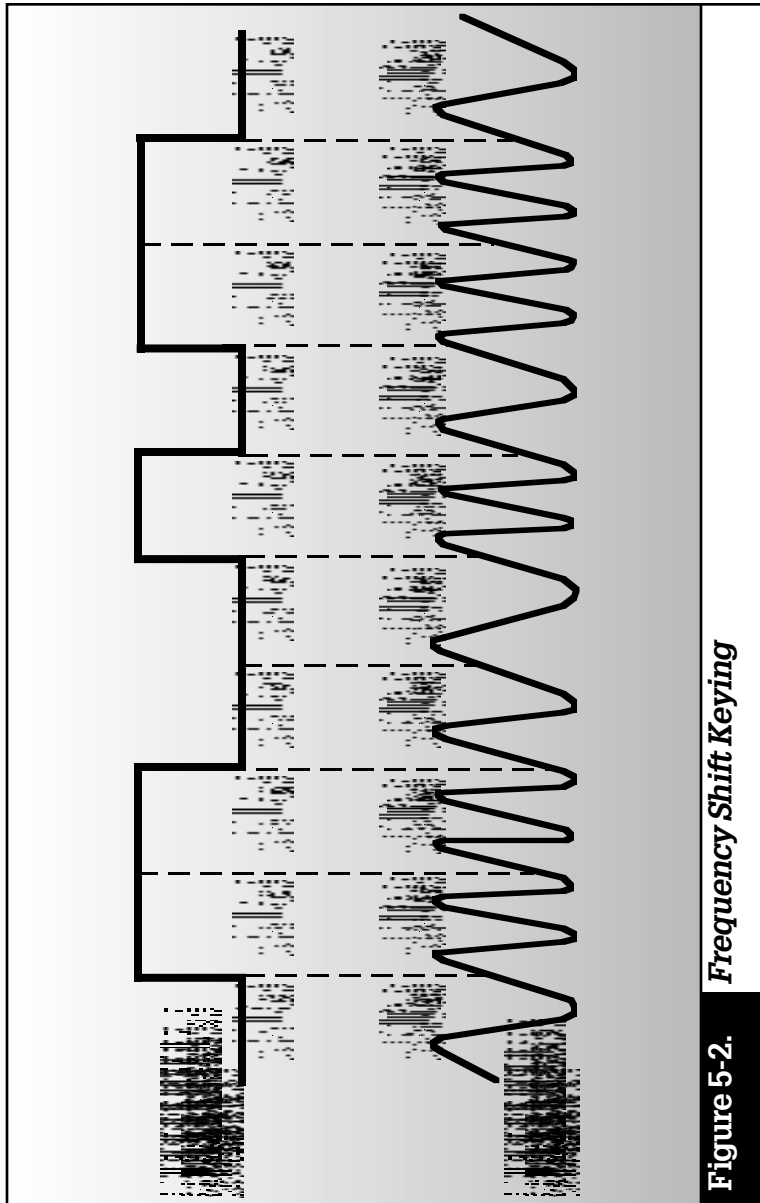

Figure 5-2. Frequency Shift Keying

modem carries information on a single audio tone. This provides vastly improved data communications on HF channels, including greater robustness, reduced sensitivity to interference, and a higher data rate with powerful forward error correction (FEC), described in the next section. Harris currently has its fourth generation of high-speed modems on the market.

Error Control

Harris RF Communication's engineers use several different approaches to avoid data transmission problems.

FEC adds redundant data to the data stream to allow the data receiver to detect and correct errors. An important aspect of this concept is that it does not require a return channel for the acknowledgment. If a data receiver detects an error, it simply corrects it and accurately reproduces the original data without notifying the data sender that there was a problem.

The FEC coding technique is most effective if errors occur randomly in a data stream. The HF medium, however, typically introduces errors that occur in bursts — that is, intervals with a high bit error ratio (BER) in the channel are interspersed with intervals of a low BER. To take full advantage of the FEC coding technique, it's best to randomize the errors that occur in the channel by a process called *interleaving* (Figure 5-3).

For example, at the modulator, the data stream enters a 9-row by 10-column matrix. The blocks are entered by rows and unloaded by columns. When the data stream leaves the matrix for transmission, the sequence of output bits will be 1, 11, 21, and so on.

At the demodulator, the process is reversed by *de-interleaving*. Data is entered by columns in a matrix identical to that at the transmitter. It is read out in rows, restoring the sequence of data to its original state. Thus, if a burst were to cause 9 consecutive bits to be in error, no more than 3 of them will fall in any 30-bit sequence of bits after de-interleaving. Then, if an FEC coding technique were used, the errors would be corrected.

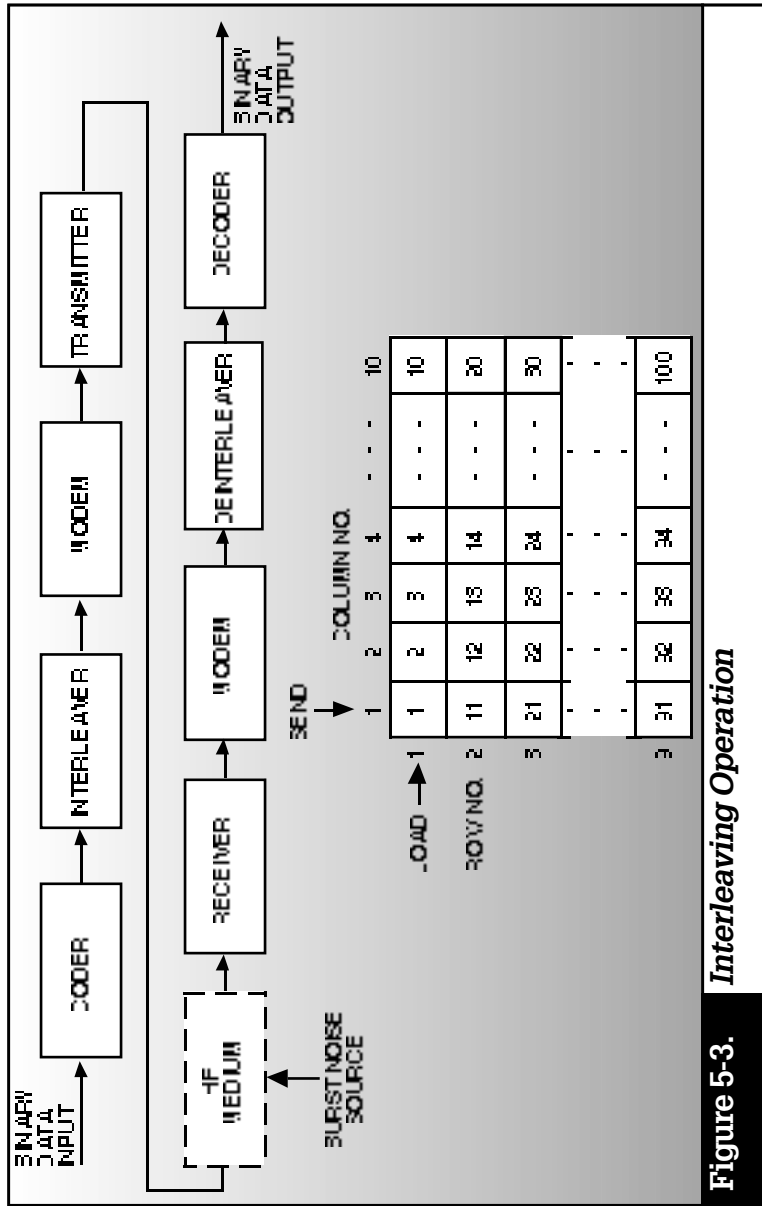

Figure 5-3. Interleaving Operation

Soft-decision decoding further enhances the power of the error-correction coding. In this process, a group of detected symbols that retain their analog character are compared against the set of possible transmitted code words. The system “remembers” the voltage from the detector and applies a weighing factor to each symbol in the code word before making a decision about which code word was transmitted.

Data communications techniques are also used for encrypting voice calls by a device called a *vocoder* (short for voice coder-decoder). The vocoder converts sound into a data stream for transmission over an HF channel. A vocoder at the receiving end reconstructs the data into telephone-quality sound.

In addition to error correction techniques, high-speed serial modems may include two signal processing schemes that improve data transmissions. An *automatic channel equalizer* compensates for variations in the channel characteristics as data is being received. An *adaptive excision filter* seeks out and suppresses narrowband interference in the demodulator input, reducing the effects of co-channel interference, that is, interference on the same channel that is being used. Harris has patented several techniques to perform these functions.

SUMMARY

- The transmission of data requires the use of modems to convert digital data into analog form when transmitting, and convert analog data back to digital form when receiving.
- HF modems are classified as slow-speed FSK, high-speed parallel tone, or high-speed serial tone.
- Serial tone modems provide vastly improved data communications on HF channels, including a higher data rate with powerful forward error correction (FEC), greater robustness, and reduced sensitivity to interference.
- FEC systems provide error correction without the need for a return link.
- Interleaving is a technique that randomizes error bursts, allowing FEC systems to work more effectively.
- Soft-decision decoding further reduces bit error rates by comparing a group of symbols that retain their analog character against the set of possible transmitted code words.
- A vocoder converts voice signals into digital data for coded transmission over HF channels.
- Automatic channel equalization and adaptive excision filtering are signal processing techniques that improve data communications performance.

ADAPTIVE RADIO TECHNOLOGY

The constantly changing properties of the ionosphere, as well as random noise and interference, cause disruptions in HF communications. In the past, a skilled radio operator was required to establish communications and to continually adjust operating parameters. Today, this function is fully automatic. Harris RF Communications provides *adaptive* radio systems, pioneered in the early '80s, that can react rapidly to changing propagating conditions and use feedback from Real Time Channel Evaluation (*RTCE*) techniques to select frequencies, adjust data rates, or change modulation schemes. Two of the many adaptive processes are Automatic Link Establishment (*ALE*) and Link Quality Analysis (*LOA*). Because of Harris' previous experience with adaptive radio technology, the company was asked to become a member of the United States Military Standard Committee to develop the ALE standard.

Automatic Link Establishment

ALE is a technique that permits HF radio stations to call and link on the best HF channel automatically without operator assistance. Harris pioneered the manufacture of adaptive communications equipment with AUTOLINK. In addition, Harris is a leader in the development of advanced ALE techniques that comply with MIL-STD-188-141A and FED-STD-1045A. (See Appendix A, Standards.)

Typically, ALE systems make use of recently measured radio channel characteristics (LOA data) stored in a memory “matrix.” The system works much like a telephone in that each radio in a network is assigned an address (ID). When not in use, each radio receiver constantly scans through its assigned frequencies, listening for calls addressed to it.

To reach a specific station, the caller simply enters an ID just like dialing a phone number. The radio consults its LOA matrix and selects the best available assigned frequency. (Further explanation of the LOA matrix appears below.) It then sends out a brief message containing the ID of the destination. When the receiving station “hears” its address, it stops scanning and stays on that frequency. The two stations automatically conduct a “handshake” to confirm that a link is established and they are ready to communicate (Figure 6-1). The receiving station, which was completely silent, will typically emit a ringing signal to alert the receiving operator of an incoming call. At the conclusion of the call, one of the stations “hangs up,” a disconnect signal is sent to the other station, and they each return to the scanning mode.

Link Quality Analysis

An HF communications system has a number of channels assigned to it. A system incorporating LOA capability selects the best channel. Here’s how it works in an adaptive system.

At prescribed intervals, a station in a network will attempt to link on each of its assigned frequencies and measure the signal quality on each linked frequency. These quality scores are stored in a matrix. When a call is initiated, the radio checks its “memory” to determine the best quality frequency for the call to the desired station. It then attempts to link on that frequency. If the link cannot be established, it will try again on the next best frequency, and so on, until a link is established.

Figure 6-2 shows a simplified LOA matrix for station BASE01. The channel numbers represent programmed frequencies, and

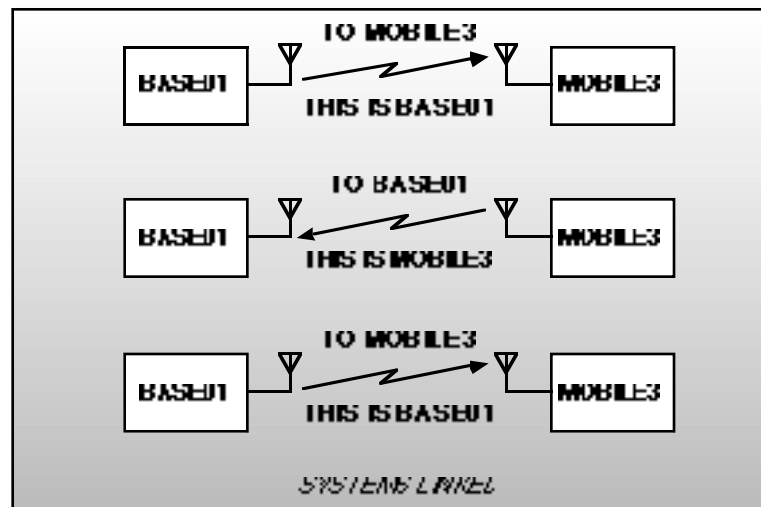

Figure 6-1. *ALE System Handshake*

ADDRESS	CHANNELS				
	01	02	04	14	18
BASE04	60	33	12	81	23
MOBILE2	10	--	48	86	21
MOBILE3	--	--	29	52	63
GBB122	21	00	00	45	--

Figure 6-2. *LOA Matrix for BASE 01*

the numbers in the matrix are the most recent channel-quality scores. Thus, if an operator wanted to make a call from BASE01 to MOBILE03, the radio would attempt to call on channel 18, which has the highest LOA score.

When making multi-station calls, the radio selects the channel with the best average score. Thus, for a multi-station call to all the addresses in the matrix, channel 14 would be selected.

Adaptive Enhancements

Adaptive radio technology is further enhanced by the use of computer controllers, which permit modem data rate selection based on channel conditions, optimum antenna choice, automatic adjustment of transmitted power level, automatic nulling and elimination of interfering signals, and selection of modem modulation and coding schemes. The benefit is that these adaptive schemes are largely automatic and improve communications without operator intervention. Thus, the requirement for an operator with high technical knowledge has been significantly reduced.

SUMMARY

- Adaptive radio technology permits modern HF radio systems to adjust automatically to changing propagation conditions.
- Automatic Link Establishment (ALE) makes it possible for HF radios to connect without operator assistance.
- Link Quality Analysis (LOA) is a method of assessing channel quality, so that connections occur on the best channel/ frequency.
- Other automatic adaptive techniques are available.

SECURING COMMUNICATIONS

We have reached the age where advancements in radio technology make communicating easy, widespread, and reliable. Now the security of the communication becomes as important as the communication itself. In this chapter, we'll discuss communications security (*COMSEC*), that is, methods that keep important communications secure. We'll also talk about transmission security (*TRANSEC*)—schemes that make it difficult for someone to intercept or interfere with your communications.

COMSEC

COMSEC uses scrambling or cryptographic techniques in order to make information unintelligible to people who do not have a need to know or who should not know. We'll differentiate here between cryptographic or ciphering techniques applied to digital signals and scrambling techniques applied to analog signals.

Cryptography is the process of *encrypting* (translating) information into an apparently random message at the transmitter and then deciphering the random message by decryption at the receiver.

Historically, sensitive information has been protected through the use of codes. The sender would manually encode the messages before transmission and the recipient would manually decode the messages upon receipt. Today's electronic technologies allow the coding/decoding process to occur automatically.

The process involves using a mathematical algorithm, coupled with a *key*, to translate information from the clear to the encrypted state. If sensitive information is transmitted without the protection of cryptography and the information is intercepted, it would require little effort or resources to understand the transmittal. The US Government has established standards for the degree of protection required for different levels of classified and sensitive information.

In voice communications systems that do not require extremely high security, you can protect against casual eavesdropping by *scrambling*. Scrambling, as an analog COMSEC technique, involves separating the voice signal into a number of audio sub-bands, shifting each sub-band to a different audio frequency range, and combining the resulting sub-bands into a composite audio output that modulates the transmitter. A random pattern controls the frequency shifting. The technique of scrambling the pattern is similar to sending a message with a decoder ring, like the ones sometimes found in children's cereal boxes. You can, for example, designate that the letter *c* be ciphered as *g*, *a* as *n*, and *t* as *w*, so that when you receive the message *gnw*, you decode it as *cat*. Descrambling occurs at the receiver by reversing the process. Harris' Analog Voice Security (AVS) allows for easy entry into the communications net because it does not require synchronization with other stations.

In digital encryption the data, which may be digitized voice (as described in Chapter 5), is reduced to a binary data stream. The cryptographic engine creates an extremely long, non-repeating binary number stream based on a traffic encryption key (*TEK*). The data stream is added to the cryptographic stream, creating the encrypted data, or *cipher text*. A binary stream created in this fashion is inherently unpredictable; it also provides a very secure method of protecting information. On the other hand, all analog signals are more predictable and thus less secure.

The data encryption strength, which is the degree of difficulty in determining the message content, is a function of the

complexity of the mathematical algorithm coupled with the key. The key is a variable that changes the resynchronization of the mathematical algorithm. Protection of the key is vital. Even if an unwanted organization gains access to the encrypted information and has the algorithm, it is still impossible to decrypt the information without the key. The US Government has developed rigorous key management procedures to protect, distribute, store, and dispose of keys.

In the past, keys were manually loaded into a cryptographic device by using a paper tape, magnetic medium, or plug-in transfer device. Creation and secure delivery of keys to each user were significant problems in both logistics and record keeping.

One type of key management system also used in the commercial sector is *public key cryptography*. Under this standard, each user generates two keys. One is the public key, "Y," and the other is the *private key*, "X." The Y value derives from the X value. The strength of such a system lies in the difficulty of deriving X from Y; what is encrypted with the Y key can only be decrypted with the X key. By openly disseminating the user's public Y key, and retaining sole access to the private X key, anyone can send a secure message to you by encrypting it with your public Y key. You are the only one, though, who can decrypt the message, since only you have the private X key.

In a network using this public key system, two-way secure communications are possible among all network users. This is called an *asymmetrical key system*. The alternative is a *symmetric key system*, in which the same key encrypts and decrypts data. Because both the originator and all recipients must have the same keys, this system offers the highest levels of security.

Harris has led the way in developing state-of-the-art electronic means to secure and distribute key material for these symmetric key-based communications systems. A recent development applicable to radio networks employs Over-The-Air-Rekeying

(OTAR). This technique nearly eliminates the need for manual loading of keys and provides a secure key management.

OTAR is based upon a benign key distribution system. It includes a key encryption key (*KEK*) used to encrypt the TEK and any other operational COMSEC or TRANSEC keys. This process is referred to as "wrapping" so as to differentiate it from traffic encryption. The KEK is the only key that must be initially loaded into both the sending and receiving units. Usually, an initial set of operational keys are loaded at the same time.

After wrapping, subsequent distribution can use any physical or electronic means. In an OTAR system, the wrapped keys are inserted into a message and sent over a radio link to the intended station using error-free transmission protocols (an error would render the keys useless). The link used for transmission is usually secured by the TEK currently in use. Thus, the key material is doubly protected when sent over the air, practically eliminating any possibility of compromise.

For a higher degree of security, it is common to digitize the voice signal by means of a vocoder, as mentioned in Chapter 5. The resulting digital signal is then treated like any data stream.

TRANSEC

TRANSEC employs a number of techniques to prevent signal detection or jamming of the transmission path. These techniques include hiding the channel or making it a moving target.

Low Probability of Detection (*LPD*) systems transmit using very low power or spread the signal over a broad bandwidth so that the natural noise in the environment masks the signal.

A related strategy, known as Low Probability of Intercept (*LPI*), involves transmitting signals in short bursts or over a wide bandwidth to reduce on-the-air time.

The most commonly used TRANSEC technique is *frequency hopping*. In this system, the transmitter frequency changes so rapidly that it is difficult for anyone not authorized to listen in or to jam the signal. The receiver is synchronized so that it hops from frequency to frequency in a predetermined pattern in unison with the transmitter. Frequency hopping scatters the intelligence over several hundred discrete frequencies. A radio operator listening to one of these frequencies may hear a short “pop” of static. A broadband receiver could perhaps capture all of these little bursts; however, the task of picking these bursts out of the other natural and man-made bits of noise would be daunting, requiring a team of experts several hours just to reassemble a short conversation. Jamming one channel would have minimal impact on the hopping communicator. To effectively jam a frequency-hopping radio, most or all of the frequencies that the hopping communicator uses would have to be jammed, thus preventing the use of those frequencies as well. Harris’ AN/PRC-117, AN/PRC-138, and RF-5000 FALCON transmitter series of products are highly rated for their frequency-hopping capabilities.

Harris’ RF Communications Secure Products Line is a preferred supplier of information security for the US Government and the US Department of Defense. It is a leader in the development and production of US Government and exportable security products. The NSA-endorsed WINDSTER Key Generator Module and SKMM (Standard Key Management Module) line of products has full OTAR capabilities and meets NSA’s rigorous Commercial COMSEC Endorsement Program requirements.

Harris’ COMSEC/TRANSEC Integrated Circuit (CTIC) and COMSEC/TRANSEC Integrated Circuit/DS-101 Hybrid (CDH) provide system embedders and US Government customers protection of highly classified information using state-of-the-art TRANSEC/COMSEC techniques. The company also provides a comprehensive line of secure products for the export market.

SUMMARY

- COMSEC uses cryptography or scrambling to make information unintelligible to people who do not have a need to know or who should not know.
 - The security level of a COMSEC system depends on the mathematical soundness of the algorithms and the number of variables in the key.
 - Protection of the key is vital to securing the transmitted information.
 - Public key cryptography is widely used in the commercial sector.
- Over-The-Air-Rekeying (OTAR) eliminates the need for manual loading of keys and provides a more secure method of key management.
- TRANSEC protects the transmitted signal itself, to prevent signal detection or jamming of the transmission path.
 - Low Probability of Detection (LPD) systems use spread-spectrum and other techniques to “hide” the signal beneath the natural noise level.
 - Low Probability of Interception (LPI) radios transmit compressed digital data in short bursts or over a wide bandwidth.
 - Frequency-hopping radio systems jump rapidly in unison, from one frequency to another in apparently random patterns, using a common timing reference.

HF SYSTEMS AND APPLICATIONS

HF radio offers a unique combination of cost effectiveness and versatility for long-haul communications. In recent years, computer technology and high-speed digital signal processing have enhanced the performance and reliability of HF communications systems, resulting in reduced operator involvement in establishing HF communications circuits.

At the same time, new technology has dramatically reduced the size and weight of HF radio equipment. Diverse capabilities, which formerly required separate pieces of equipment, are now combined and embedded into the radio transceiver itself.

Examples of HF Communications Systems

Harris Corporation, RF Communications Division, designs, manufactures, and installs turnkey radio communications systems for worldwide government, military, and commercial markets. Here are some examples of how these HF systems come together in a modern communications network to meet complex communications needs.

Secure Data System

Figure 8-1 shows a typical secure HF data transmission system, which can be used whenever it is necessary to transfer data securely between two points. The serial modem, which uses FEC coding, also provides real-time channel equalization and data interleaving for protection against fading, and automatic excision

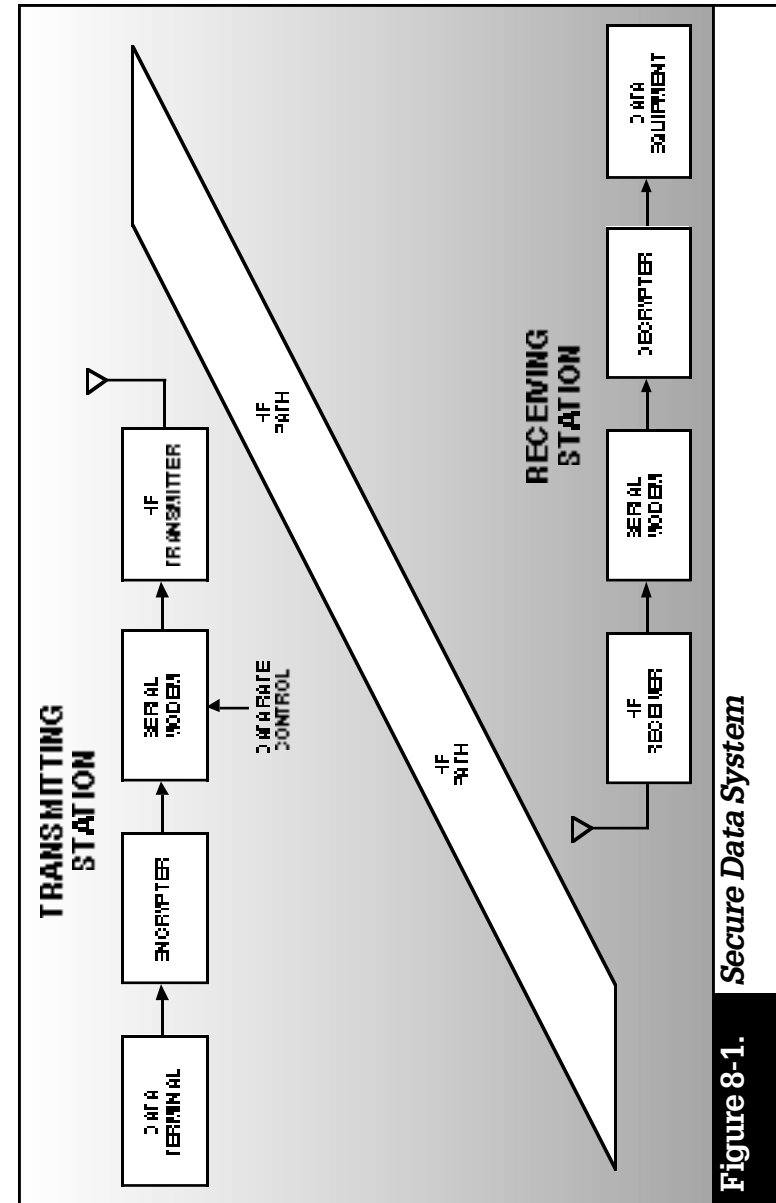

Figure 8-1. Secure Data System

filters remove interference from up to four sources. The transmit modem data rate adjusts to the terminal data rate and is selected on the basis of an LQA (estimate of channel quality). The amount of coding (redundancy) used in the FEC varies as a function of the selected modem data rate. Thus, if poor channel quality is predicted, a relatively low data rate and a more powerful FEC code will be designated.

Country-Wide HF Data Communications System

A country-wide HF data communications system, which provides economical, long-range communications, is shown in Figure 8-2. The HF data communications system links a fixed central communications center and 12 subordinate stations located throughout the country. The system incorporates an ALE capability that offers fully automatic operation with unattended processing of incoming messages.

Each subordinate station has additional HF and VHF radios that provide voice and data communications to mobile stations in its vicinity. In the data communications mode, an ARQ message protocol is used for error detection and correction. The central station is a fixed installation with separate transmit and receive control sites. Intersite communications and control are via microwave or a landline link.

HF Telephone System

An HF radio link can extend the reach of a telephone network, as shown in Figure 8-3. The system operates much like the cordless telephone widely used in homes today, but covers hundreds of thousands of miles using HF radio. The HF telephone system enables users to place calls to and from mobile radio transceivers into the commercial switched telephone network or private subscriber telephone lines.

Calls from the field can be placed over HF, VHF, or UHF to anywhere in the world through the base station telephone switch or exchange. To initiate a call, the user enters a telephone number

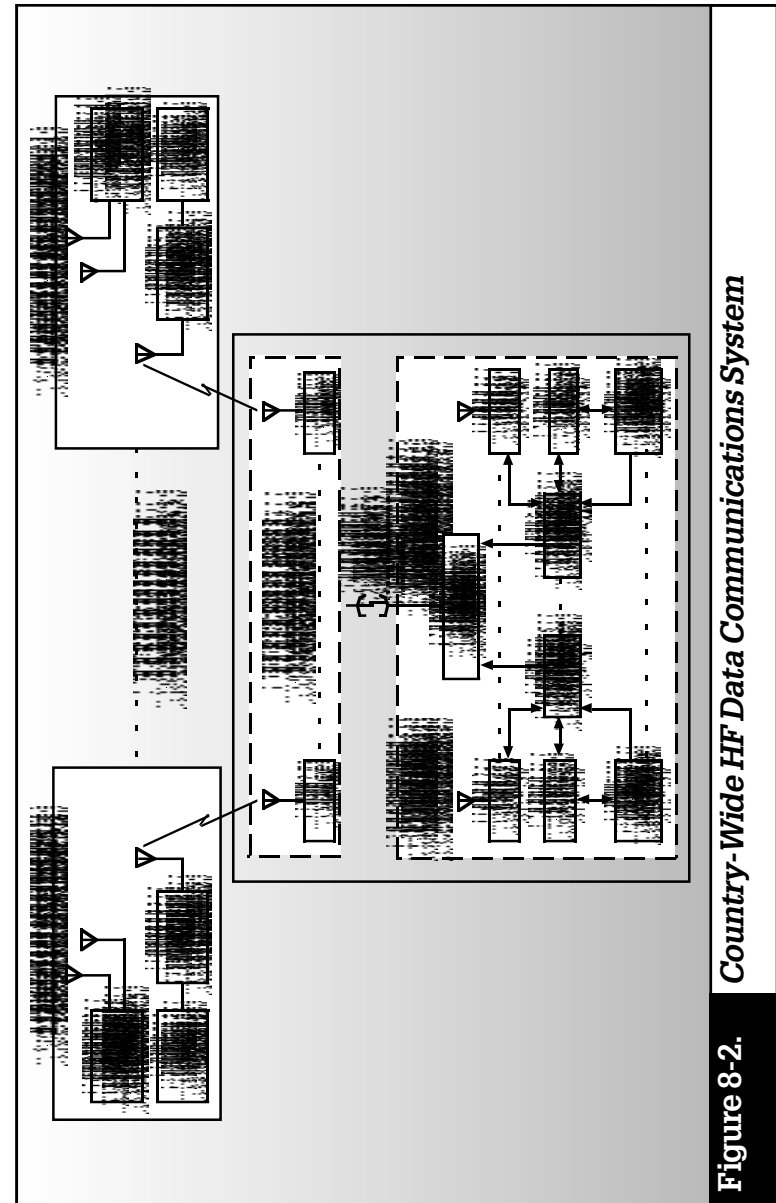

Country-Wide HF Data Communications System

Figure 8-2.

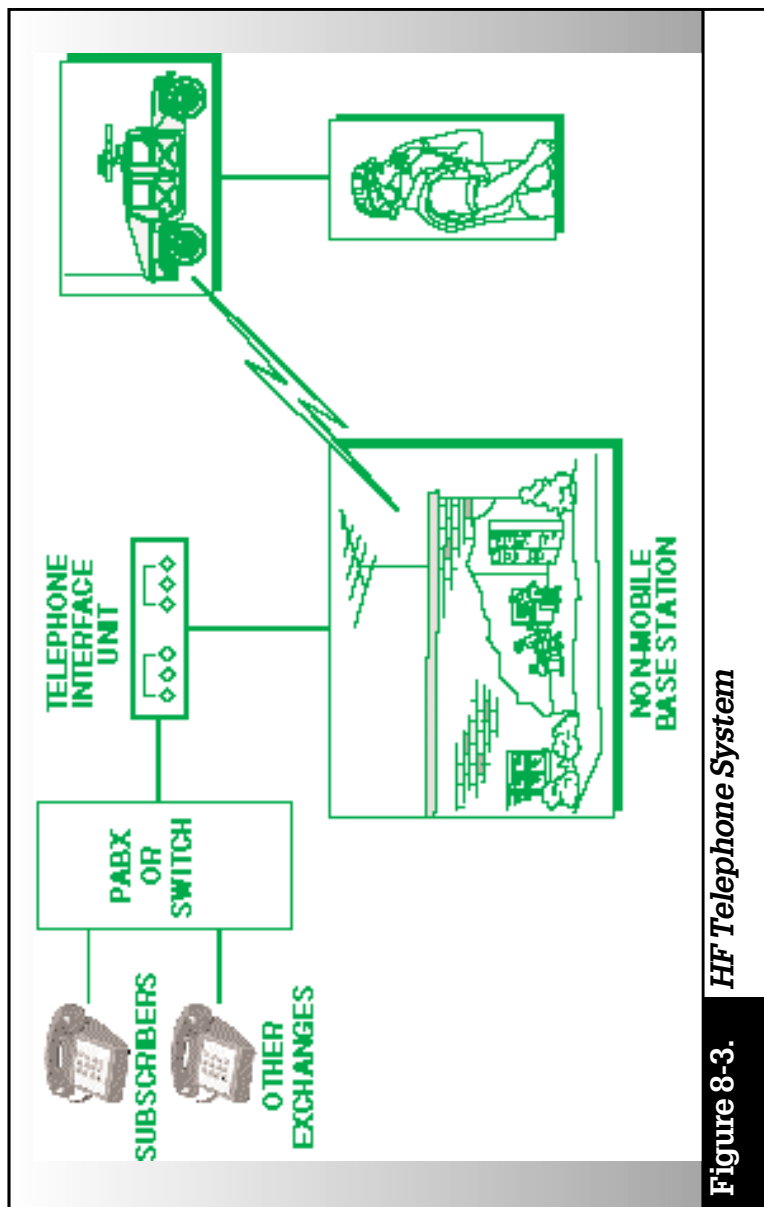

Figure 8-3. HF Telephone System

just as if the Remote Access Unit (RAU) were a telephone set connected directly to the base station telephone exchange.

At this point, the number dialed is transmitted through the RAU to the Telephone Interface Unit (TIU). As the TIU dials the digits and the telephone rings, call progress tones are heard by the mobile operator. In order to contact anyone in the field, a telephone user dials a telephone number (or the extension) to which the TIU is connected — from anywhere in the world. The call is automatically answered by the TIU and the user is connected directly with the field radio.

Ground-to-Air Communications System

Figure 8-4 is a block diagram of a ground-to-air communications system with a split-site ground station capable of simultaneous data, facsimile, or voice communications with up to four airborne platforms. This system dedicates one ground-based receiver-transmitter pair and an associated controller to ALE. Once a ground-air link is established, the station controller hands off the traffic channel to another receiver-transmitter pair. This system also incorporates the cordless telephone capability described above. Thus, an airborne platform has access to the telephone network. Each aircraft incorporates an HF transceiver with built-in ALE controller and data modem, plus a 400-watt solid-state power amplifier and antenna coupler. Intersite communications between receiver and transmitter sites are via radio or landline.

HF Digital Video Imaging Communications System

This system captures, digitizes, and transmits video images in near real time from a mobile unit to a base station via an HF data link. Figure 8-5 shows a scenario in which an unattended still-video camera sends images to an imaging terminal via a fiber-optic link. The terminal captures and digitizes the image and sends the data to a modem in the transceiver, which relays the data to the base. Communications may be via a two-way link that uses an ARQ protocol to obtain error-free transmission of

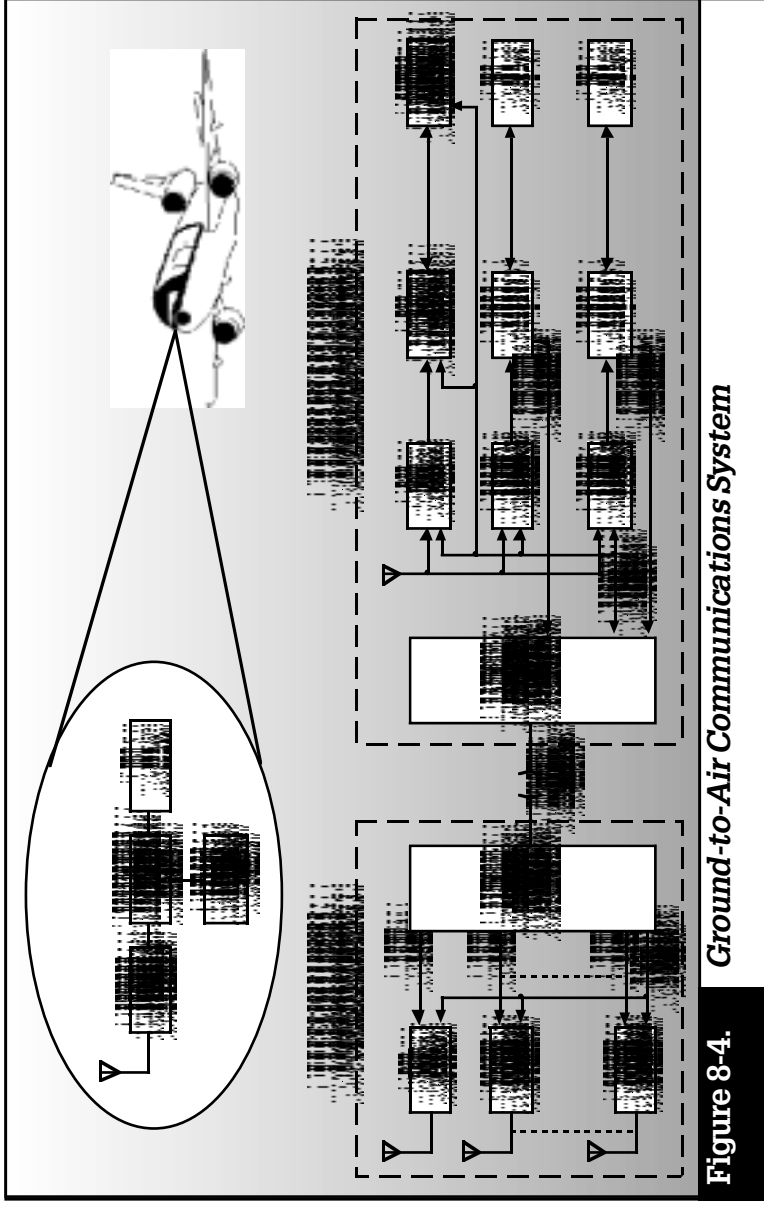

Figure 8-4. Ground-to-Air Communications System

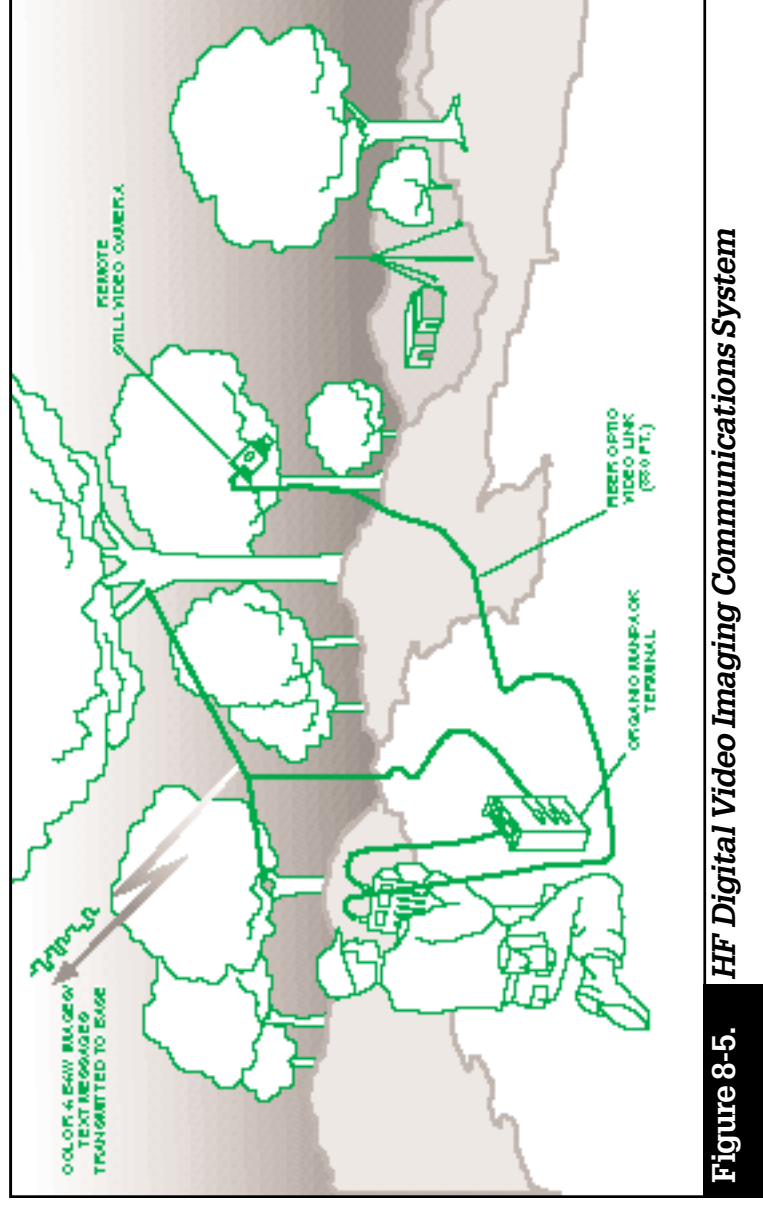

Figure 8-5. HF Digital Video Imaging Communications System

the image, or a one-way link in which FEC coding reduces the probability of error in the received message.

Broadband Transmitter System

The biggest HF communication problem that must be solved on board large naval ships is how to run multiple HF transmit and receive circuits simultaneously without interfering with each other, and that all circuits operate through a very few number of antennas (due to size and space limitations). Harris has developed the optimum solution to these problems with its ultra-linear *broadband* transmitting system. Harris' system also supports rapid frequency changes through use of ALE and frequency hopping. Figure 8-6 is a simplified block diagram of a solid-state transmitter system capable of delivering up to 4 kW in the 2- to 30-MHz frequency range into an antenna. Signals from up to eight independent audio sources modulate HF exciters. The outputs of the exciter route through a signal distribution unit into a bank of linear solid-state power amplifiers, each capable of delivering 500 watts. The signal distribution unit allows various combinations of exciter signals to be applied to the power amplifiers, so that, for example, the signal from a single exciter may be applied to all eight amplifiers. The amplifier outputs are added in a passive power combiner and supplied to an antenna.

HF Tactical Communications Network

Figure 8-7 shows a portion of a tactical communications network that provides coverage over distances ranging from less than 50 miles to more than 1,500 miles. In a network of this type, the individual elements include frequency hopping, encryption, and ALE capabilities. Network requirements dictate that links are provided between the fixed headquarters site and fixed installations for quasi-permanent military regions and zones. Provisions are made for communications between headquarters and task forces at fixed, non-permanent installations. Lower echelon communications have a combination of fixed, mobile, and man-portable equipment. Frequency management of the network is a headquarters responsibility.

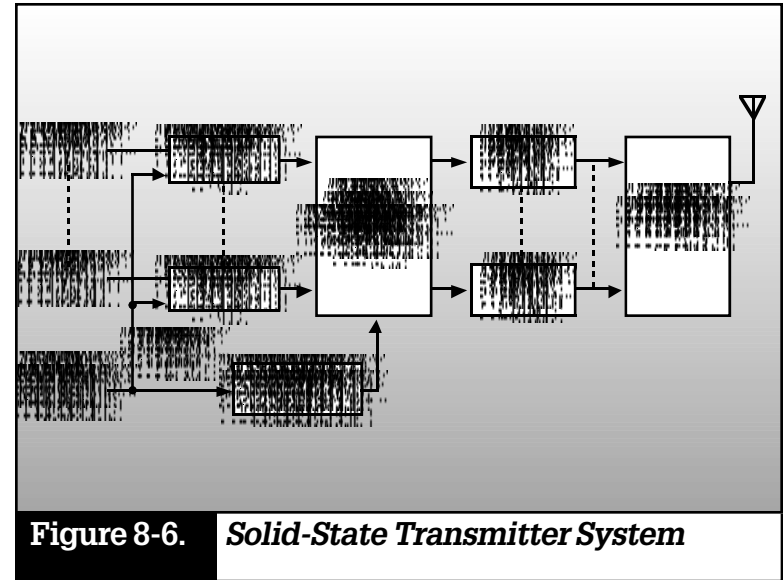

Figure 8-6. *Solid-State Transmitter System*

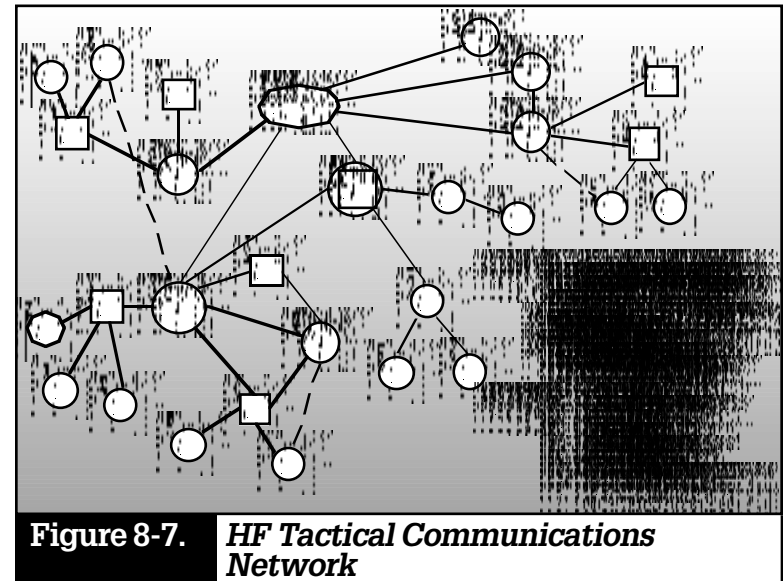

Figure 8-7. *HF Tactical Communications Network*

HF E-Mail and Inter-Networking

Electronic mail and other inter-networking technologies are becoming increasingly important for interoffice communications. However, many users find that communications between remote stations are difficult and/or expensive, due to costly telephone or satellite charges. Harris' HF radios and systems are an excellent alternative for providing these services to distant users or stations. Typical applications include:

- Naval ship-to-shore and ship-to-ship communications.
- Embassy Ministry of Foreign Affairs communications.
- Oil/Gas/Mining operations.

In the following discussion, we will focus on naval applications; similar configurations support other HF E-mail and inter-networking communications system requirements.

An HF E-mail system for naval ships and deployed forces that supports naval communications, including administrative, logistic, and engineering order-wire traffic, is shown in Figure 8-8.

A typical shipboard HF E-mail system consists of a Harris RF-6750 Wireless Gateway, an RF-7210 ALE Controller, an RF-5710 High-Speed HF Modem, and connection to a Harris HF radio system (the RF-590A Receiver and RF-1140 Transmitter). The modem and radio system are remotely controlled and managed by the Wireless Gateway computer.

The RF-6750 Wireless Gateway provides seamless data transfers between common networked applications, such as E-mail and FTP file transfer, running on geographically separated Local Area Networks (LANs). This system also supports the application of sending mobile HF data messages over the Internet. The data transfers are accomplished automatically using HF radio. Unlike conventional network routers and gateways, the RF-6750 is designed specifically to operate over HF radio circuits.

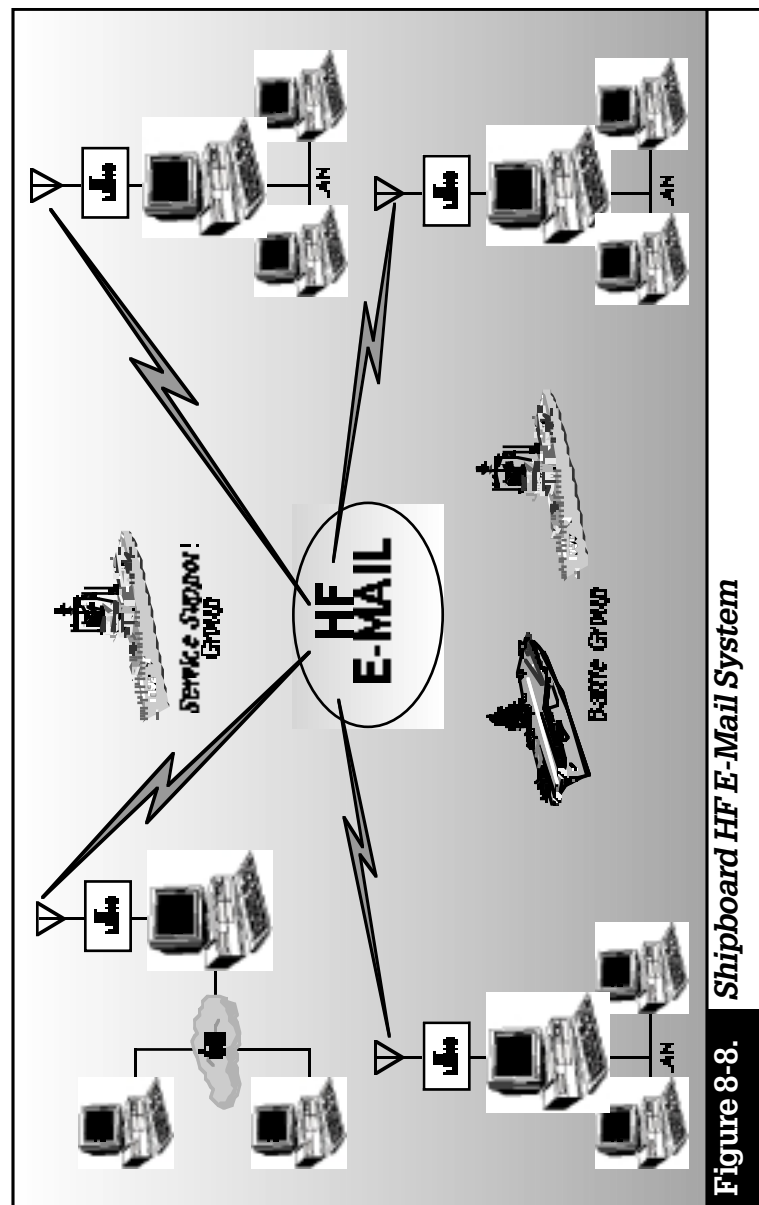

Figure 8-8. Shipboard HF E-Mail System

System Design Considerations

Harris' RF Communications Division has a communications systems engineering department staffed by engineers who are specialists in the design of custom equipment for the "one-of-a-kind" type of application. The following are some of the factors that we consider in designing a modern HF radio system.

System definition

- Who are the users?
- What is their location?
- Are communications one-way or two-way?
- What are the interfaces with other communications media?
- What is the operating environment (hostile or friendly, rural or urban)?

Transfer of information

- What type of traffic is there (voice, data, images)?
- Do the priority levels differ, depending on the message source and/or content?
- What are the security levels for safeguarding the information?

Message protection and security

- What is the correct type of *error detection* and correction for data?
- What type of COMSEC is needed?
- Will spread-spectrum or frequency-hopping techniques be used to avoid interception or jamming?
- Is excision filtering needed to remove interfering signals?

System availability

- What is the probability of transferring messages in real time?
- Can alternate routing be used to enhance message availability?
- Can lower priority traffic use *store-and-forward* techniques?
- Are there any operational restrictions due to propagation, transmitter power, or other constraints?

Traffic analysis

- What are the typical message lengths?
- What is the average number of messages per unit of time?
- What are the message priorities?
- When is the peak traffic?
- What are the types of traffic?

Projected growth for each category of traffic

- What impact do higher traffic levels have on system implementation?
- Are additional nodes and/or relays necessary?

Impact on message structure

- Is the format for data message compatible with traffic requirements?
- Include security classification, priority, source, and destination address.

Site

- Is this a fixed or mobile site?

Fixed site

- Are the receiving, transmitting, and control functions collocated or separate?
- Is this a permanent or temporary installation?
- Are there any frequency restraints for collocated receivers and transmitters?
- What are the staffing requirements?
- What are the environmental considerations?
- What type of power is available?
- Is uninterrupted power a requirement?

Mobile site

- Is the equipment designed for a vehicle, ship, shelter, or aircraft?
- Are manpacks required?
- What are the antenna limitations and constraints?
- What are the physical size constraints?
- What are the bandwidth and primary power requirements?
- What are the environmental considerations?

Communications protocol

- Is there a return channel for ARQ?
- Is ALE being used?
- What are the data protocols?

Equipment selection

- Transmitter requirements: Power output, solid state versus tube, broadband or narrowband, allowable distortion, frequency range, tuning speed, remote control?
- Receiver requirements: Selectivity, dynamic range, distortion, remote control?
- Antenna requirements: Gain, bandwidth, polarization, radiation pattern, available terrain, remote control?

Data communications systems

- What is the data rate?
- How is data being protected (interleaving, encryption)?
- What is the modulation scheme?
- Is the modem serial or parallel tone?

Interface to other equipment and systems

- What other equipment is required (fax, data terminal, imaging systems)?
- What other types of systems are involved?
- Is there an interface with VHF/UHF radio systems, satellite, or switched telephone networks?

Command and control

- Will operation be attended or unattended?
- Is self-test required?
- Are the transmitter, receiver, and control sites at different places (split site)?

SUMMARY

- Modern HF radio is small and lightweight. Features and capabilities, which formerly required additional equipment, are now embedded into the radio transceiver.
- HF radio plays a key role in modern long-range telecommunications systems, often working in conjunction with other media, such as satellites, cellular networks, and telephone landlines.
- A systems approach is needed to obtain the best results in designing a modern HF radio communications network.

FUTURE DIRECTIONS

In the earlier chapters, we presented the principles of HF communications, and gave you some insight into where the technology of HF communications has been and where it is now.

Today, and for the future, HF radio fills two roles. First, it is the primary medium for long-haul communications, where there is a need for a mobile or quickly deployable system to support emergency or military operations. Second, it is a highly cost-effective alternative and backup to other communications media, such as telephone and satellite systems. In either capacity, HF has to support a variety of traffic, including voice, data, and images.

Advances in digital signal processing (*DSP*) technology will lead to continued improvements in HF systems and equipment. In particular, we expect to see advances in the following areas:

ALE Performance

Higher-speed devices allow more precise and frequent link-quality analysis, enabling better and faster frequency selection. Also, higher ALE system data rates allow faster transmission of channel-quality information.

Modem Design

Adaptive channel equalization improvements will allow increases in channel bit rates to up to 9600 bps in a 3-kHz channel, giving HF communication an economical advantage over other long-haul communications media. Also, for certain less restricted applications allowing greater than 3-kHz bandwidth, transmission of 64 kbps can be achieved over HF.

Advances in DSP devices improve adaptive filtering, which in turn combats unintentional interference and jamming. Modem capabilities will expand so that waveforms will be optimized for use, not only with HF, but for other frequencies in the next generation of multi-band radios.

Networking

Improvements in HF system performance and computer-based technology provide networks that achieve highly reliable levels of communications through automatic message routing and adaptive signaling techniques. Network design includes ways to determine periodically the link quality between each pair of its stations at each of their assigned frequencies, and send this information to all nodes so that they route messages automatically. Thus, if station A transmits a message to B, a routing algorithm determines if direct point-to-point communication is possible or whether the message from A to B must be routed through other stations.

The ability to transfer information over a network enables simultaneous transfer of several messages or speeds up the transfer of long messages. For example, multiple radios in a station simultaneously send messages to several destinations over several channels. Also, a long message can be divided so that portions of it can be sent in parallel. If channel bandwidths increase beyond the current 3-kHz restriction (which requires international agreement), improvements in real-time channel equalization techniques will allow data transmission rates considerably higher than the current rate of 9600 bps.

HF radio is becoming an increasingly important element in multi-media networks that incorporate landline, VHF, and UHF. Recent and projected improvements in HF communications technology mean that constraints on the passing of information through networks that include an HF leg will be significantly reduced.

Radio Design

Radios will continue to move toward multi-band designs, ranging from MF through UHF in a single radio.

Digital circuits will continue to replace analog circuits, resulting in lower costs and more versatile and reliable designs. Digital processing circuitry will handle higher and higher frequencies, as higher speed analog-to-digital converters and other DSP circuits become available.

The versatility, made possible by “going digital,” allows radios to be quickly reprogrammed for broadband modes of operation, resulting in new levels of performance, such as higher data rates and improved frequency-hopping capabilities.

APPENDIX A — Standards

HF communications standards, created by the US Government, NATO, and other organizations, greatly influence the design of HF equipment and systems. These standards apply to equipment specifications, waveform design, communication protocols, and computer control. They serve to:

- Ensure interoperability among systems used by different organizations.
- Reduce ambiguous descriptions of equipment and systems by providing a common language in equipment specifications and in defining the operating environment.
- Allow more accurate comparison between different equipment by defining test conditions.

A summary of some of the most important HF radio communication standards are:

- Federal Standard 1045A, HF Radio Automatic Link Establishment. Specifies automated radio features, including frequency scanning, selective calling, ALE, LOA, and sounding, which ensure interoperability of radio systems.
- Federal Standard 1052, HF Radio Modems. Defines design objectives for data modems and performance requirements for a data link protocol compatible with the ALE standards established by FED-STD 1045A.
- MIL-STD-188-100 Notice 1, Common Long Haul and Tactical Communications System Technical Standards. Specifies requirements for interconnecting long-haul and tactical systems for voice and data service.

- MIL-STD-188-110A, Interoperability and Performance Standards for Data Modems. Establishes requirements and design objectives that ensure specified levels of performance of voice-frequency data modems used in communications systems.
- MIL-STD-188-141A, Interoperability and Performance Standards for Medium- and High-Frequency Radio Equipment. Establishes requirements and design objectives that ensure interoperability and specified levels of performance for HF radio equipment. Includes details about implementing ALE systems, waveforms, signal structures, protocols, and LOA.
- NATO STANAG 4285, Characteristics of 1200/2400/3600 bps Single-Tone Modulators/Demodulators for HF Radio Links. Defines the parameters that ensure interoperability between single-tone modems designed for communicating via HF radio links at bit rates of 1200, 2400, or 3600 bps.
- NATO STANAG 4529, Modification of NATO STANAG 4285 to deliver data and voice in 1240 Hz bandwidth.

APPENDIX B — GLOSSARY

ADAPTIVE EXCISION FILTER A signal-processing technique that improves data transmissions. It seeks and suppresses narrowband interference in the demodulator input and reduces the effects of co-channel interference (interference on the same channel that is being used).

ADAPTIVE SYSTEM A system that automatically adjusts its parameters to improve its performance in response to changing conditions.

AGC (Automatic Gain Control) — Circuit employed to vary gain or amplifier in proportion to input signal strength so that output remains at a constant level.

ALE (Automatic Link Establishment) — A technique that permits radio stations to make contact with one another automatically.

AM (Amplitude Modulation) — A technique used to transmit information in which the amplitude of the radio frequency carrier is modulated by the audio input and the full carrier and both sidebands are transmitted.

AME (Amplitude Modulation Equivalent) — A method of single sideband transmission where the carrier is reinserted to permit reception by conventional AM receivers.

AMPLITUDE The peak-to-peak magnitude of a radio wave.

ANTENNA COUPLER/TUNER A device between the transmitter and antenna that modifies the characteristics of the load presented to the transmitter so that it transfers maximum power to the antenna.

ANTENNA DIRECTIVE GAIN The ratio of radiation intensity in a certain direction to the average radiation intensity.

ANTENNA POWER GAIN The ratio of radiated power in a given direction to the antenna input power.

ARQ (Automatic Repeat Request) — Data transmission technique for error-free data transfer.

ASCII (American Standard Code for Information Interchange) — The standard code for digital data interchange. ASCII uses a coded character set consisting of a 7-bit coded character (8 bits including parity check).

ASYMMETRICAL KEY SYSTEM A key management system that allows two-way secure communications among all users that have a public key and a private key.

ASYNCHRONOUS A data communication system that adds start-and-stop signal elements to the data for the purpose of synchronizing individual data characters or blocks.

ATMOSPHERIC NOISE Radio noise caused by natural atmospheric processes (primarily by lightning discharges in thunderstorms).

AUTOMATIC CHANNEL EQUALIZER A signal processing technique that improves data transmissions by compensating for variations in the channel characteristics as data is received.

BANDPASS FILTER A filter that passes a limited band of frequencies. It is used to remove noise and spurious signals generated in the exciter or output frequency harmonics from the power amplifier.

BANDWIDTH The range of frequencies occupied by a given signal.

BASEBAND The frequency band occupied by a signal prior to radio frequency carrier modulation or following demodulation.

BAUD A unit of signaling speed equal to the number of symbols, i.e., discrete signal conditions per second.

BER (Bit Error Ratio) — The number of erroneous bits divided by the total number of bits communicated.

BINARY Number system having base of 2, using only the symbols 0 and 1.

BIT One binary digit (0 or 1).

BLOS (Beyond Line-of-Sight) — Communications that occur over a great distance.

BROADBAND A term indicating the relative spectrum occupancy of a signal as distinguished from a narrowband signal. A broadband signal typically has a bandwidth in excess of twice the highest modulating frequency. Synonym: Wideband.

CARRIER A radio frequency signal that may be modulated with information signals.

CCIR (International Radio Consultative Committee) — An organization of the International Telecommunications Union (ITU) that studies technical questions related to radio communications.

CHANNEL A unidirectional or bidirectional path for transmitting and/or receiving radio signals.

CIPHER TEXT Encrypted data.

COLLOCATION The act or result of placing or arranging side by side.

COMSEC (Communications Security) — Scrambling or cryptographic techniques that make information unintelligible to unauthorized persons.

COSMIC NOISE Random noise originating outside the earth's atmosphere.

CRYPTOGRAPHY A COMSEC technique that translates (encrypts) information into an apparently random message and then interprets (deciphers) the random message by decryption.

CW (Continuous Wave) — A radio wave of constant amplitude and constant frequency. Also, Morse code.

D LAYER First layer in the ionosphere. Reaches maximum ionization when the sun is at zenith and dissipates quickly toward sunset.

dB (Decibel) — The standard unit for expressing transmission gain or loss and relative power ratios.

DE-INTERLEAVING Process used by a demodulator to reverse interleaving and thus correct data transmission errors used in FEC coding.

DEMODULATION The process in which the original modulating signal is recovered from a modulated carrier.

DIPOLE ANTENNA A versatile antenna that is usually a wire fed at the center of its length. Its orientation provides either horizontal or vertical polarization.

DIRECT WAVES Travel in straight line, becoming weaker as distance increases.

DIRECTIONAL ANTENNA An antenna that has greater gain in one or more directions.

DSP (Digital Signal Processing) — A recently developed technology that allows software to control digital electronic circuitry.

DTMF (Dual-Tone-Multi-Frequency) — Refers to DTMF signaling, which is typically used in telephone systems.

E LAYER The mid-level of the ionosphere which reaches maximum ionization at noon. It begins dissipating toward sunset and reaches minimum activity at midnight. Irregular cloud-like formations of ionized gases occasionally occur in the E layer.

EMI (Electromagnetic Interference) — An electromagnetic disturbance that degrades communications performance .
Synonym: Radio Frequency Interference (RFI).

ENCRYPTION Process of translating information into an apparently random message.

ERP (Effective Radiated Power) — Equivalent power transmitted to the atmosphere, which is the product of the transmitter power output multiplied by the gain of the antenna.

ERROR DETECTION An error correction technique that uses binary code words to modify data messages by systematically adding check bits to detect errors in received words.

EXCITER The part of the transmitter that generates the modulated signal for a radio transmitter.

F LAYER The uppermost and most heavily ionized region of the ionosphere. Important for long-haul communications, since this layer remains ionized even after sunset.

FADING The variation of the amplitude and/or phase of a received signal due to changes in the propagation path with time.

FEC (Forward Error Correction) — A system of error control for data transmission whereby the receiver can correct any code block that contains fewer than a fixed number of bits in error.

FM (Frequency Modulation) — A form of modulation where the frequency of a carrier varies in proportion to an audio modulating signal.

FOT (Frequency of Optimum Transmission) — The highest frequency predicted to be available for sky wave transmission for a given path and time for 85 percent of the maximum usable frequency (MUF).

FREQUENT The number of completed cycles per second of a signal, measured in hertz (Hz).

FREQUENCY HOPPING The rapid switching (hopping) of radio system frequency for both the receiver and transceiver from frequency to frequency in apparently random patterns, using a common timing reference.

FSK (Frequency Shift Keying) — A form of modulation in which a digital signal shifts the output frequency between discrete values.

GAIN The ratio of the value of an output parameter, such as power, to its input level. Usually expressed in decibels.

GROUND REFLECTED WAVE The portion of the propagated wave that is reflected from the surface of the earth between the transmitter and receiver.

GROUND WAVE A radio wave that is propagated over the earth and ordinarily is affected by the presence of the ground.

HF (High Frequency) — Nominally, the band from 3 to 30 MHz; in practice, the lower end of the HF band extends to 1.6 MHz.

Hz (Hertz) — Basic unit for frequency.

IF (Intermediate Frequency) — A frequency used within equipment as an intermediate step in transmitting or receiving.

IMPEDANCE Opposition to current flow of a complex combination of resistance and reactance. Reactance is the opposition to

AC current flow by a capacitor or an inductor. An ideal antenna coupler will act so as to cancel the reactive component of antenna impedance, i.e., by providing an equal inductive reactance if the antenna has a capacitive reactance or an equal capacitive reactance if the antenna presents an inductive reactance.

INCIDENT ANGLE The angle at which sky waves enter the ionosphere.

INTERLEAVING A technique that increases the effectiveness of FEC codes by randomizing the distribution of errors in communication channels characterized by error bursts.

IONCAP (Ionospheric Communications Analysis and Prediction) — A popular and effective propagation prediction program that predicts system performance at given times of day as a function of frequency for a given HF path and a specified complement of equipment.

IONOSPHERE A region of electrically charged particles or gases in the earth's atmosphere extending from 50 to 600 kilometers (approximately 30 to 375 miles) above the earth's surface.

IONOSPHERIC SOUNDING An automated propagation prediction technique.

ISB (Independent Sideband) — Double sideband transmission in which the information carried by each sideband is different.

JAMMING Deliberate interference that results from transmission on operating frequencies with the intent to disrupt communications.

KEK (Key Encryption Key) — Used in digital encryption.

KEY A variable that changes the mathematical algorithm in cryptography.

KEY GENERATOR A device or process that generates the variable for a cryptographic encoding system.

LOS (Line of Sight) — A term that refers to radio signal propagation in a straight line from the transmitter to a receiver without refraction; generally extends to the visible horizon.

LPD (Low Probability of Detection) — Techniques for minimizing the probability that the transmitted signal is detected by an unauthorized party.

LPI (Low Probability of Intercept) — Techniques for minimizing the likelihood of the intelligence on a transmitted signal being recovered by an unauthorized party.

LQA (Link Quality Analysis) — A technique for real-time channel evaluation in which radios measure and store values indicating the relative quality of a radio link at different assigned frequencies.

LUF (Lowest Usable Frequency) — The lowest frequency in the HF band at which the received field intensity is sufficient to provide the required signal-to-noise ratio.

MAIN LOBE In an antenna radiation pattern, the lobe containing the direction of maximum radiation intensity.

MFSK (Multi-tone Frequency Shift Keying).

MODEM (MOdulator-DEmodulator) — A device that modulates and demodulates signals. The modem converts digital signals into analog form for transmitting and converts the received analog signals into digital form.

MODULATION The process, or result of the process, of varying a characteristic of a carrier in accordance with a signal from an information source.

MUF (Maximum Usable Frequency) — The upper limit for the frequencies used at a specified time for radio transmission between two points via ionospheric propagation.

MULTIPATH The propagation phenomenon that results in radio signals reaching the receiving antenna by two or more paths.

MULTIPATH SPREAD The range of timed differences that it takes for radio signals to reach the receiving antenna when they arrive from several routes, which may include one or more sky wave paths and/or a ground-wave path. The effect of multipath spread is minimized by selecting a frequency as close as possible to the MUF.

NVIS (Near-Vertical Incidence Sky wave) — A technique for transmitting over relatively short ranges by ionospheric refraction using very high incident angles.

OHM Unit of measurement of resistance. Its symbol is Ω .

OMNIDIRECTIONAL ANTENNA An antenna whose pattern is non-directional in azimuth.

ON-OFF KEYING Turning the carrier on or off with telegraph key (Morse code). Same as CW.

OTAR (Over-The-Air-Rekeying) — This technique developed by Harris eliminates the need for manual loading of encryption keys and provides a more secure method of key management.

PARALLEL TONE MODEM Carries information on simultaneous audio tones, where each tone is modulated at a low-keying rate.

PHASE In a periodic process such as a radio wave, any possible distinguishable state of the wave.

POLARIZATION The orientation of a wave relative to a reference plane. Usually expressed as horizontal or vertical in radio wave terminology.

POWER AMPLIFIER The part of the transmitter that boosts the output power of the radio signal to the desired wattage before sending it to the transmitting antenna.

PREAMBLE A known sequence of bits sent at the start of a message which the receiver uses to synchronize to its internal clock.

PROPAGATION The movement of radio frequency energy through the atmosphere.

PUBLIC KEY CRYPTOGRAPHY A type of key management system used in the commercial sector. Under this standard, each user generates two keys, a public key and a private key. The strength of such a system lies in the difficulty of deriving the private key from the public key.

RADIATION PATTERN Pattern determined by an antenna's design and strongly influenced by its location with respect to the ground. Radiation patterns are frequency dependent.

RAU (Remote Access Unit).

REFRACTION The bending of a radio wave as it passes obliquely from one medium to another.

RMS (Root Mean Square).

RTCE (Real-Time Channel Evaluation) — Techniques used to select frequencies, adjust data rates, or change modulation schemes in adaptive radio systems.

SATCOM (Satellite Communications).

SCRAMBLING A COMSEC technique that involves separating the voice signal into a number of bands, shifting each band to a different audio frequency range, and combining the resulting bands into a composite audio output that modulates the transmitter.

SERIAL TONE MODEM Carries digital information on a single audio tone.

SHORT WAVE Radio frequencies above 3 MHz.

SID (Sudden Ionospheric Disturbance) — Abnormally high ionization densities caused by solar flares, resulting in a sudden increase in radio wave absorption.

SIDEBAND The spectral energy, distributed above or below a carrier, resulting from a modulation process.

SKY WAVE A radio wave that is reflected by the ionosphere.

SNR (Signal-to-Noise Ratio) — The ratio of the power in the desired signal to that of noise in a specified bandwidth.

SOFT-DECISION DECODING An error-correction technique where a group of detected symbols that retain their analog character are compared against the set of possible transmitted code words. A weighing factor is applied to each symbol in the code word before a decision is made about which code word was transmitted.

SPORADIC E Layer found in the E Layer of the ionosphere. Supports propagation of sky waves at the upper end of the HF band and beyond.

SPREAD SPECTRUM A technique used to overcome deliberate radio communications interference, in which the modulated information is transmitted in a bandwidth considerably greater than the frequency content of the original information.

SSB (Single Sideband) — A modulation technique in which the carrier and one sideband (upper or lower) are suppressed so that all power is concentrated in the other sideband.

STORE AND FORWARD A technique where information is stored until a communication link is established and then sent.

SUNSPOT CYCLE Eleven-year cycle of sunspots which generate bursts of radiation that increase levels of ionization.

SURFACE WAVES Travel along the surface of the earth and may reach beyond the horizon.

SYMMETRIC KEY SYSTEM A key management system in which the same key encrypts and decrypts data.

SYNCHRONOUS A form of data communications that uses a preamble to alert the data receiver that a message is coming and to allow it to synchronize to an internal bit clock.

TAKE-OFF ANGLE The angle between the axis of the main lobe of an antenna pattern and the horizontal plane at the transmitting antenna.

TEK (Traffic Encryption Key) — Used in digital encryption.

TIU (Telephone Interface Unit).

TRAFFIC The information moved over a communications channel.

TRANSCEIVER Equipment using common circuits in order to provide transmitting and receiving capability.

TRANSEC (Transmission Security) — Techniques that prevent signal detection or jamming of the transmission path.

VERTICAL WHIP ANTENNA An omnidirectional antenna that has low take-off angles and vertical polarity.

VOCODER A device that converts sounds into a data stream that can be sent over an HF channel. Short for voice coder-decoder.

WAVELENGTH Distance between point on loop of wave to corresponding point on adjacent wave.

FURTHER READING

We hope this book is helpful in introducing you to the concepts and benefits of HF radio technology. For more information, here's some recommended reading:

Mayor, Jonathan L. (1992). *The Radio Amateur's Digital Communications Handbook*. Blue Ridge Summit, Pa.: TAB Books.

Laster, Clay. (1994). *The Beginner's Handbook of Amateur Radio*. Blue Ridge Summit, Pa.: TAB Books

Sabin, W. E. (1995) *Single Sideband Systems and Circuit*. New York, NY.: McGraw-Hill

Schetgen, Robert (Ed.). *The ARRL Handbook for Radio Amateurs, 1995*. Newington, Conn.: Amateur Radio Relay League.

Straw, Dean. *The ARRL Antenna Book, 1995*. Newington, Conn.: Amateur Radio Relay League

We would appreciate your input. Did you enjoy this introduction? Did you find it interesting and informative? Would you like to hear more about other radio products such as antennas or multi-band radio? Our goal is to educate and inform you. Let us know if we were successful!

To contact us:

By Phone: **(716) 244-5830**
Marketing Communications Manager

By Mail: **Harris Corporation**
RF Communications Division
1680 University Avenue
Rochester, New York 14610

By Fax: **(716) 244-2917**

By Web: **<http://www.harris.com/rfc>**